



# ***MULTIRACK***<sup>TM</sup>

**Optic / Thermistor Rack Control For Trucks**

**MODEL 688 SHOP MANUAL**



# **MULTIRACK™**

## **Optic / Thermistor Rack Control For Trucks**

### **MODEL 688 SHOP MANUAL**

#### **TABLE OF CONTENTS**

##### **1.0) INTRODUCTION**

##### **2.0) 688 *MULTIRACK™* OPERATION AND FEATURES**

- 2.1) Overview
- 2.2) MultiRack Gauge Module Operation
- 2.3) MultiRack Controller Operation
- 2.4) Installation

##### **3.0) 688 *MULTIRACK™* INSTALLATION GUIDE**

##### **4.0) TROUBLESHOOTING GUIDE**

- 4.1) Overview
- 4.2) Gauge Module
- 4.3) Fibre Cable
- 4.4) Controller
- 4.5) Rack Socket

##### **5.0) SERVICE AND WARRANTY INFORMATION**

## **1.0) INTRODUCTION**

Congratulations on purchasing the Garnet Instruments Model 688 MultiRack Optic / Thermistor Rack Control for Trucks. The 688 represents the state of the art in multi-function overfill control for transport applications. The MultiRack is used in conjunction with either a SeeLevel or SeeLevel Special truck gauge to allow trucks to load at facilities controlled by either optic style (five wire) and thermistor style (two wire) loading racks. The MultiRack will shut down the loading rack when the product level reaches the programmed shutdown point in the SeeLevel gauge.

The MultiRack will withstand the vibration, shock, moisture, and temperature extremes encountered in transport applications. It is housed in a durable, weatherproof housing and will operate over an ambient temperature range of -40 C to +60 C (-40 F to +140 F).

The MultiRack does not require any 12V truck power to operate, it functions entirely on battery and rack power. Built in diagnostic lights simplify troubleshooting and monitor the connection to the loading rack.

## 2.0) 688 **MULTIRACK™** OPERATION AND FEATURES

### 2.1) Overview

For the 810PS SeeLevel gauge, the MultiRack system consists of a 688M MultiRack Driver Module (or 888 Universal Driver Module if the Model 815 SpillStop Overfill Prevention System is also installed), a fibre optic interconnect cable, and a 688S (single compartment) or 688D (dual compartment) rack controller. The gauge module is installed inside the SeeLevel and connected to alarm 4. For the 808PA SeeLevel Special gauge, only a 688M MultiRack Driver Module is needed. In both cases, the fibre optic cable carries a pulsed light signal from the module to the rack controller to tell it to permit loading. The rack controller is wired to the appropriate sockets for connection to the loading rack. When the gauge detects an overfill situation, the pulse light signal is turned off by the module and the rack controller goes to non-permit, which shuts down the loading rack.

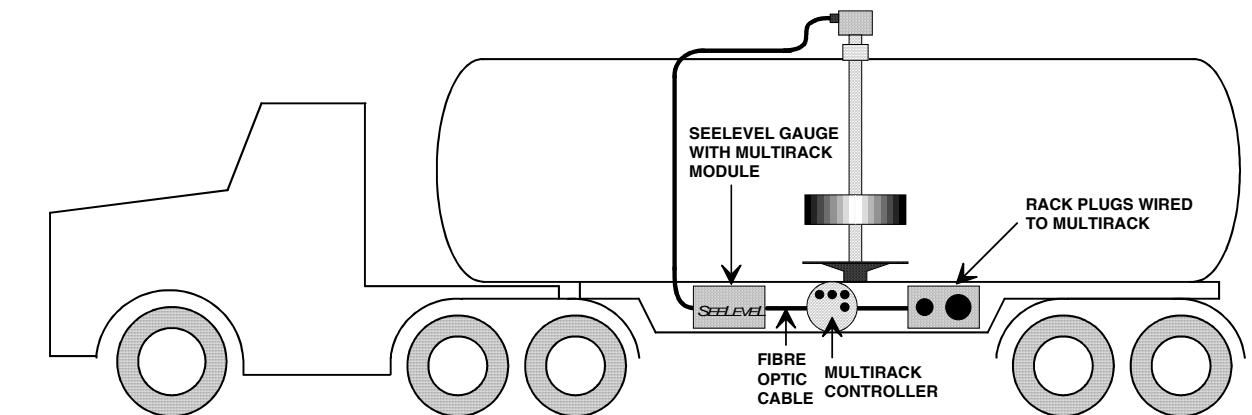

### 2.2) Driver Module Operation

The 888 Universal Driver Module contains both a standard SpillStop gauge module as well as the optical transmitter for the MultiRack. The module, installed into a small plastic box, is attached into the SeeLevel gauge enclosure, and the SpillStop portion of the module functions exactly the same as the standard SpillStop module. The MultiRack portion of the module uses alarm point 4 to operate, which is programmed to shut down at the overfill point. When the SeeLevel float rises above the overfill point, alarm 4 shuts down and the optical output from the module stops, which makes the controller go to non-permit. Older models of the 810 have a terminal block on a circuit board mounted in the base of the enclosure and the 888 will have pins that are installed into the terminal block.

The MultiRack portion of the module operates from a lithium battery with a 10 year lifetime. If the battery goes dead, the module defaults to non-permit. The SpillStop portion is unaffected by the battery.

The 688M MultiRack Driver Module contains only the optical transmitter for the MultiRack, since the SpillStop module is built into the 808PA. The module mounts inside the 808PA display

enclosure and connects to the black ground wire and yellow alarm wire from the 808PA. Alarm 4 is programmed to operate the MultiRack, the same as for the 810 model.

### 2.3) Rack Controller Operation

The rack controller connects to the module via fibre optic cable and goes to permit only if the light pulse is present. The fibre cable is used to provide electrical isolation between the SeeLevel and the intrinsically safe wiring of the loading rack. The controller will only accept light pulses from a 888 or 688M module, it cannot be fooled by ambient light or the output from a sender bar. The controller operates entirely from rack power, it contains no batteries, and will function only when connected to an optic or thermistor rack.

If the truck has two trailers, then one controller is required per trailer, since the fibre optic cable cannot be connected between trailers. The single controller has one fibre input, and it is used for single compartment applications. The dual controller has two fibre inputs, and it is used for two compartment applications, and both fibre inputs must receive light pulses for the controller to permit.

The controller can operate either an optic (five wire) or a thermistor (two wire) loading rack. If the application has two trailers, then the optic portions of the two controllers are series wired just like optic probes. The controller has two thermistor leads to simulate two thermistor probes, and will operate with either one or both of the thermistor leads connected. For two trailer applications, each of the thermistor leads from the rack socket is connected to its own controller. The controller simulates a two wire thermistor regardless of product temperature, the third temperature compensation (rack green) lead is not used.

The controller is mounted in a round Betts junction box with a snap lid, providing excellent sealing against weather conditions, as well as visibility of the diagnostic LEDs. The cover of the controller is illustrated on the next page.

The OPTIC diagnostic LED indicates proper connection to the optic rack, it will illuminate whenever the ground and red power wires are connected, regardless of whether the controller is in permit or not. The OPTIC LED does not indicate whether the yellow or orange pulse leads are connected.

The THERM A and THERM B diagnostic LEDs indicate proper connection to the thermistor rack, regardless of whether the controller is in permit or not. If only one of the thermistor leads is used, then only its corresponding LED will illuminate.

The PERMIT diagnostic LED will light when the controller is in permit and is connected to either an optic or thermistor rack. It will not illuminate if the controller is not connected, since the rack is the controller power source.

**WARNING: To maintain overflow protection, the operator MUST verify float movement of the SeeLevel (or SeeLevel Special) at the start of loading each compartment. If any skipping of calibration points is observed, discontinue loading until the problem is corrected. Please refer to the manuals for these instruments for further details.**

## 2.4) Installation

Installation of the system consists of connecting the appropriate module into the gauge and programming alarm point 4. The controller enclosure is mounted, connected via fibre optic cable to the module, and wired to the rack sockets(s). Verification of system operation completes the installation.

## 3.0) 688 **MULTIRACK**<sup>™</sup> INSTALLATION GUIDE

- 3.1) Install the SeeLevel/SeeLevel Special systems as described in their respective manuals.
- 3.2) Make sure that the correct controller has been chosen. For applications with a single compartment per trailer, use the single fibre input model. For two compartments per trailer, use the dual fibre input model. One controller is needed for each individual trailer.
- 3.3) Pick a spot to mount the controller and the rack socket(s). They should be close together, easy to access, and out of direct road spray.
- 3.4) Drill and tap holes into the controller enclosure for the needed connections. There will be one hole for the fibre from the gauge, and at least one for the wiring to the rack socket(s). Make sure that none of the entries are at the top of the box, since the LEDs will get in the way of the wires and water is more likely to leak in from the top. Also, make sure that the holes are located to allow room for the cap to fully seat, since it sticks into the box by about 3/8". **Be very careful when penetrating the box**, the drill will want to shoot into the box once you break through the inside. If you drill off a wire or fibre connector it will **NOT** be covered by warranty.
- 3.5) Mount the controller enclosure using the mounting flange holes, being certain to shim the enclosure away from the mounting surface with the spacers provided to allow water drainage. **Broken controller enclosures caused by water freezing behind the enclosure are NOT covered by warranty.**
- 3.6) Connect the 688M Driver Module into the gauge enclosure. For the 810PS SeeLevel ProSeries gauge, the module is encapsulated into a small black box. Silicone this box into the left side of the aluminum enclosure. Before the silicone sets, make sure that the gauge faceplate can still seat properly. Connect the yellow module wire to the red Alarm 4 wire from the gauge and connect the black module wire to the green ground wire on the gauge. For the 808PA SeeLevel Special the module is not in a box. Simply use a spot of RTV to secure the module inside the enclosure. Connect the yellow wire on the module to the yellow wire from the gauge and the black module wire to the gauge's black ground wire. You will need one module per gauge.
- 3.7) Route 1/4" Nylon air brake hose from the gauge to the controller and fasten with **brass inserts** and **compression fittings** at each end. **At the lowest point in the air line insert a T fitting with approximately two feet of Synflex hanging down to provide a drain for any water than may get into the system. If a T fitting is not feasible, put a fitting into the bottom of the display enclosure and route the 2 feet of Synflex from there.**

- 3.8) Feed the fibre optic cable through the hose, leaving about 8 inches extra at each end. Cut the fibre ends square with a sharp knife. Insert the fibre into the connectors at each end and tighten the connector lock nuts.
- 3.9) Mount the rack socket(s) and wire the rack socket(s) to the controller wires. The controller is wired as though it were a probe. The wiring pattern for the rack socket(s) should be verified with the loading rack facility. The wiring code for the controller is as follows:

<u>COLOR</u>	<u>FUNCTION</u>	<u>PROBE EQUIVALENT</u>
Red	Optic power	Optic probe red wire
Yellow	Optic pulse input	Optic probe yellow wire
Orange	Optic pulse output	Optic probe orange wire
Black	Optic & thermistor ground	Optic probe black wire Thermistor probe white wire
Green	Thermistor lead #1	Thermistor probe black wire
Green	Thermistor lead #2	Thermistor probe black wire

For dual trailer applications, wire the optic portion of the two controllers in series as though they were probes (reds and blacks together in parallel, yellow and orange in series). Wire the thermistor portion with a black probe lead from the rack socket to a green lead on a controller. The white probe ground leads from the socket connect to the controller black ground leads. The green temperature compensation probe leads from the socket are not connected.

- 3.10) Refer to the proper gauge manual and program alarm point 4 as SHUT DOWN at the desired overfill point.
- 3.11) Connect a sensor tester to each of the rack sockets and verify proper rack shutdown by lifting the floats, or simulating float movement with a programmer.
- 3.12) Inspect the controller enclosure cap for casting flash, and lightly sand or scrape off any casting protrusions. Make sure that the rubber O ring is in place and has grease on it. Orient the cap so that the holes for the LEDs line up with the holes in the label and then snap on the cap.
- 3.13) Record the truck unit number, compartment number, and the level of the rack shutdown point in the IMPORTANT OPERATOR INFORMATION area on the front page of the owners manual. **The truck operator must be given the owners manual upon delivery with all front page data filled in.**

The following wiring diagram illustrates a B-train with a single compartment lead equipped with a SeeLevelL, and a dual compartment pup equipped with SeeLevelL Specials.

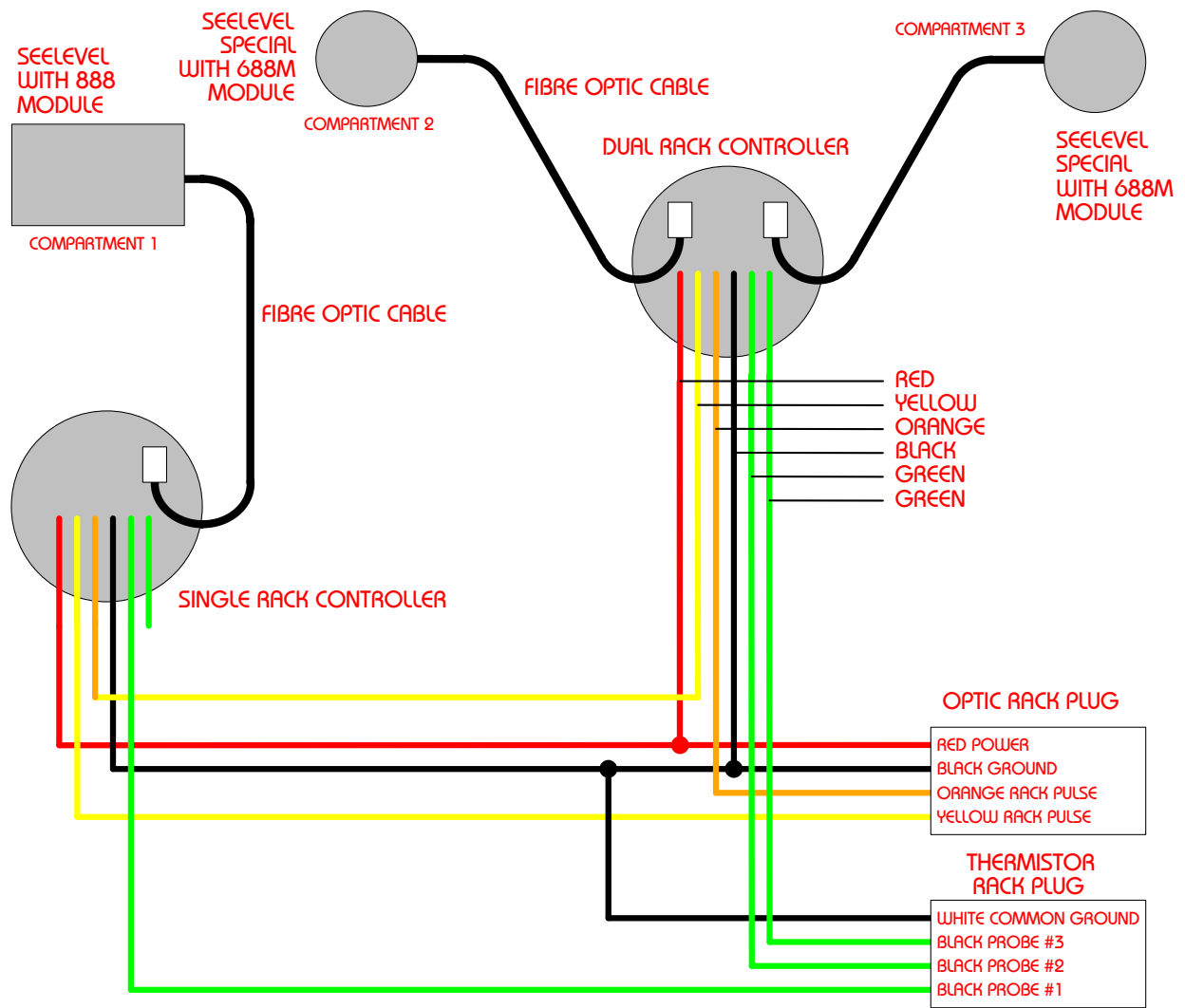

## **4.0) TROUBLESHOOTING GUIDE**

### **4.1) Overview**

There are only 4 serviceable components to the system: the 888/688M module, the interconnecting fibre optic cable, the controller, and the third party rack sockets and wiring. Make sure that the compartment is in fact empty and that the SeeLevel or SeeLevel Special gauges are working correctly. To test the various components, substitute a known good component to see if the rest of the system is working.

### **4.2) Driver Module**

The battery in the 888/688M module should last for 10 years, and is not user serviceable. If the controller is non-permissive, check the light output from the module, it should flash about 4 times per second if the gauge is telling it to. If it is not flashing, jumper alarm point 4 to ground (888), or connect the two wires from the module together (688M), this should make it flash. If not, the module is defective. If it does flash, the gauge alarm point 4 is not working, it may need to be programmed or serviced.

### **4.3) Fibre Cable**

If the module produces a light pulse but it does not reach the controller, replace the fibre cable.

### **4.4) Controller**

If the controller is non-permissive, check to make sure it is receiving light pulses from the fibre(s). Dual controllers need pulses from both fibres to permit. If the optic or thermistor diagnostic LEDs are on, but the permit light is off when the controller is receiving light pulses, replace the controller.

If the controller diagnostic LEDs are not on, check for voltage (using a voltmeter or Garnet TrackDown Tester) at the optic red wire or green thermistor wire. If the controller is getting power and ground, but does not light, replace it.

If the controller shows permit but does not allow loading, check the signals around the controller with a Garnet TrackDown Tester. If the controller does not pass the optic pulse, or if it is getting thermistor power but does not produce a pulse, replace the controller.

### **4.5) Rack Socket**

The most likely cause of a non-permit situation is a bad rack socket connection. For a thermistor rack, if the diagnostic LED is on in the controller, then the socket connection is good. For an optic rack, the pulse input and output are not monitored (since the pulse width is so small, the LEDs would not be visible), so even though the LED is on there may still be a connection problem. The Garnet TrackDown tester is the best equipment to use to trace the pulse through the system.

## **5.0) SERVICE AND WARRANTY INFORMATION**

The warranty will apply only if the warranty card shipped with the equipment has been returned to Garnet Instruments Ltd.

Garnet Instruments Ltd. warrants equipment manufactured by Garnet to be free from defects in material and workmanship under normal use and service for a period of one year from the date of sale from Garnet or an Authorized Dealer. The warranty period will start from the date of purchase or installation as indicated on the warranty card. Under these warranties, Garnet shall be responsible only for actual loss or damage suffered and then only to the extent of Garnet's invoiced price of the product. Garnet shall not be liable in any case for labor charges for indirect, special, or consequential damages. Garnet shall not be liable in any case for the removal and/or reinstallation of defective Garnet equipment. These warranties shall not apply to any defects or other damages to any Garnet equipment that has been altered or tampered with by anyone other than Garnet factory representatives. In all cases, Garnet will warrant only Garnet products which are being used for applications acceptable to Garnet and within the technical specifications of the particular product. In addition, Garnet will warrant only those products which have been installed and maintained according to Garnet factory specifications.

### **LIMITATION ON WARRANTIES**

These warranties are the only warranties, expressed or implied, upon which products are sold by Garnet and Garnet makes no warranty of merchantability or fitness for any particular purpose in respect to the products sold. Garnet products or parts thereof assumed to be defective by the purchaser within the stipulated warranty period should be returned to the seller, local distributor, or directly to Garnet for evaluation and service. Whenever direct factory evaluation, service or replacement is necessary, the customer must first, by either letter or phone, obtain a Returned Material Authorization (RMA) from Garnet Instruments directly. No material may be returned to Garnet without an RMA number assigned to it or without proper factory authorization. Any returns must be returned freight prepaid to: Garnet Instruments Ltd., 284 Kaska Road, Sherwood Park, Alberta, T8A 4G7. Returned warranted items will be repaired or replaced at the discretion of Garnet Instruments. Any Garnet items under the Garnet Warranty Policy that are deemed irreparable by Garnet Instruments will be replaced at no charge or a credit will be issued for that item subject to the customer's request.

If you do have a warranty claim or if the equipment needs to be serviced, contact the installation dealer. If you do need to contact Garnet, we can be reached as follows:

Garnet Instruments Ltd.  
288 Kaska Road  
Sherwood Park, Alberta  
Canada T8A 4G7  
E-mail: [tstalker@garnetinstruments.com](mailto:tstalker@garnetinstruments.com)