

GARNET
INSTRUMENTS LTD.

SEELVEL SPECIALTM
Gauge for Trucks

MODEL 808PSi SHOP MANUAL

REVISION 3



SEELLEVEL SPECIAL[™] Gauge for Trucks

MODEL 808PSi SHOP MANUAL

REVISION 2

TABLE OF CONTENTS

- 1) OVERVIEW**
- 2) NEW FEATURES OF THE 808PSi COMPARED TO THE 808i**
- 3) GAUGE DESCRIPTION**
- 4) UNIQUE FEATURES**
- 5) SENDER BAR LIMITS OF RESISTIVITY**
- 6) 808PSi INSTALLATION GUIDE**
- 7) SENDER BAR PROGRAMMING**
- 8) 808PSi PROGRAMMING INSTRUCTIONS**
- 9) TROUBLESHOOTING GUIDE**
- 10) SERVICE AND WARRANTY INFORMATION**

CHAPTER 1

OVERVIEW

Congratulations on purchasing the Garnet Instruments Model 808PSi SeeLevel Special™ Gauge for Trucks. The SeeLevel represents the state of the art in liquid level measurement equipment for transport applications. The SeeLevel is designed for reliable, accurate level measurement of sour or sweet crude oil, chemicals, acids, water, condensate, gasoline, or diesel fuel. The liquid level is determined by sensing the position of a magnetic float using a series of reed switches arranged in a vertical sensing bar. This technology has no moving parts except for the float, and can operate over a range of product temperatures from -40 °C to +90 °C (-40 °F to +194 °F).

The SeeLevel has been designed to withstand the vibration and shock encountered in mobile applications.

The SeeLevel can display in any units, such as inches of level, gallons, barrels, or cubic metres of volume.

The 817 Truck Gauge Programmer is used to program the SeeLevel to read the desired calibration units. It is designed to be easily operated by people unfamiliar with electronics or computers.

CHAPTER 2

NEW FEATURES OF THE 808PSi COMPARED TO THE 808i

The 808PSi has some enhancements over the 808i series. It uses new technology in the display to provide a number of new features:

- 1) The display can be programmed with a magnet for 8 or 11 bit operation, to work with bars in either 1/3, 1/4, or 1/6 inch mode. If a sender bar ends up in the wrong mode, then the display will show bad light and the number of bits received. The previous displays would not accept bars in 11 bit (1/6 inch) mode. The mode is stored in the display in the same secure memory as the calibration.
- 2) The display has improved diagnostics:
 - a) If the wrong number of bits are received, then the display shows "bL:xx" where xx is the number of bits actually received.
 - b) By connecting together the two pins on the top side of the programming plug (looking at the back of the display), the display will show a basic inch calibration, which aids in troubleshooting to determine if the sender bar or display calibration is at fault.
 - c) If there is a fault during programming or if the memory is not functioning correctly, the display shows "Err".
 - d) If the memory does not have a valid value for the number of received bits (either 8 or 11) then the display shows "Prob".
 - e) If the display has no fiber connected and is exposed to strong light the display will show "Sun" indicating that sunlight is affecting the display. If a flickering light gets into the display opto then the display may show either "Sun" or "bL:xx" depending on the exact nature of the light getting in.
- 3) The optical receiver has been improved so it cannot be overloaded with too much light from the sender bar.
- 4) The fiber optic connector is field replaceable, so if it is broken or fails, the display can be quickly returned to service.
- 5) The display has a dimming switch that can be connected so the intensity of the LED's can be reduced at night. A switch must be wired from the blue wire to ground.
- 6) An on/off switch has been supplied so it can be turned off while not in use.
- 7) Power supplied to the gauge is hard wired from the trucks battery.

CHAPTER 3

GAUGE DESCRIPTION

The SeeLevel gauge consists of a sender bar, a donut shaped float, a fiber optic interconnect cable, and a display. The sender bar is mounted vertically in the tank with the float sliding up and down around it in accordance with the fluid level. The sender bar sends the fluid level information via fiber optic cable to the display, which displays the level in appropriate units.

The float contains magnets which activate reed switches inside the stainless steel sender bar to indicate the level of the fluid. The activated switches are detected by the microprocessor at the top of the bar. The microprocessor operates from a long life lithium battery giving about 10 years of life. The level information is relayed through the fiber optic cable to the display, the fiber being used to maintain electrical isolation between the sender bar and the display, allowing operation in flammable liquids.

The display converts the level information to volume according to the calibration programmed into it with the 817 Truck Gauge Programmer. The calibration can be in inches or volumetric units such as cubic metres or barrels. The tank level is shown on an LED (Light Emitting Diode) display which gives excellent visibility. The display operates from 12 volt truck power. The entire display is contained in a small enclosure which is suitable for the tight confines of today's cabs.

Installation of the gauge consists of cutting a hole in the top of the tank and welding in a 1 inch coupler, and welding an anchor assembly to the bottom of the tank. The sender bar is cut to length, the end is sealed, and it is inserted from the top of the tank and fastened at the top with a compression fitting. The display is mounted at a convenient spot in the cab, and Synflex air brake hose is connected from the sender head to the display to house the fiber optic cable. The cable is connected at each end, and the gauge is programmed. Snapping on the cover on the head and connecting the display faceplate complete the installation. The bar can be removed later for service by disconnecting the fiber, unscrewing the compression fitting, and pulling it out.

Because of the requirement that the fiber optic cable be one continuous piece, and since the display is for in-cab use only, the 808PSi system is recommended for body mounted tanks only.

CHAPTER 4

UNIQUE FEATURES

The SeeLevel gauge has been designed for maximum ease of installation and servicing, and for best operational features. The anchor at the bottom of the tank provides a shock mount for the float, and holds the float in place while the bar is removed so no tank entry is required for sender bar replacement. If the new sender bar is cut to the same length as the old, no re-calibration is required.

The float is molded from polyethylene for high chemical resistance, good esthetic appearance, and high durability due to the "give" in the plastic. The light weight of the polyethylene allows the float size to be minimized while allowing it to float on the lowest density products.

The sender bar has no moving parts and is completely filled with potting material to enhance reliability. The use of a digital rather than analog sensing technique lowers power consumption to permit battery operation, and ensures high accuracy with no drift or degradation. To accommodate different tank sizes, the bar is simply cut to length with a hacksaw, and the cut end sealed with a cap to prevent moisture or product contamination. This way only one size needs to be stocked, and a perfect fit is ensured. The sender head is very low in profile to satisfy rollover requirements; the maximum height is less than 5 inches above the top of the tank so that it will not protrude above the spillway. The bar is programmed for 1/3" or 1/6" resolution by holding an ordinary magnet (included with the operator's manual) under the head for a specific period of time; this can be done in the field if necessary. The resolution information is stored in three separate memories for security, but if for some reason this information is lost, the sender bar automatically defaults to 1/3".

The single fiber optic cable connecting the sender head to the display can be disconnected at both ends. There is approximately 10 times as much light as is required for operation available for the fiber, so no special fiber end preparation is required. The fiber ensures that even with faulty wiring into the display, no explosion hazard can exist.

The small size of the display box also makes it easy to find an appropriate mounting location. The bright LED's ensure that the gauge display is always visible, regardless of ambient lighting conditions.

The use of an on-site programmer eliminates downtime waiting for factory calibration parts, and allows easy reprogramming should the need arise. The entire display, including decimal point, is completely programmable to whatever units are desired. In addition to numbers, the letters F, U, L, and E can be programmed to provide displays such as FULL, E, etc.

During night operations it may be desirable to reduce the brightness of the LED display. This is done by toggling the Dimming Switch on the right side of the display.

CHAPTER 5

SENDER BAR LIMITS OF RESISTIVITY

The temperature of the product being transported should be limited to approximately +90 °C (+194 °F). Damage to the float and sender bar can occur if this value is exceeded.

The tube used in the manufacturing of the sender bar is seamless 316 stainless steel. **It should be noted that certain corrosive products, as well as high concentrations of acid products, may attack the stainless steel and cause perforations to develop. It is the operator's responsibility to determine the products compatibility with the sender bar.**

WARNING: Perforation of the sender bar or heat damage is not warrantable.

The Loctite products used to secure the end cap can be attacked by certain chemicals as well. For reference, a chemical resistance chart from Loctite showing product compatibility with various chemicals can be found on the following pages.

The 680 retaining compound we specify is similar to Loctite #592, 567, 565, 569, 545, 580, 571, 242, 577, 572, 542, 565, 545, 243. If you require more information, please call the Loctite Corporation, in Canada, 1-800-263-5043, in USA, 1-800-562-8483.

LOCTITE

FLUID COMPATIBILITY CHART

for metal threaded fittings sealed with Loctite® Sealants

LIQUIDS, SOLUTIONS & SUSPENSIONS

LEGEND:

● Use Loctite #592, 567, 565, 569, 545, 580, 571, 242, 577, 572, 542, 565, 545, 243

† Use Loctite #277, 271, 554, 270, 277, 554

■ Not Recommended

□ <10% (same as ●)

>10% (same as †)

* <5% (same as ●)

<5% (same as †)

Abrasive Coolant ●
Acetaldehyde ●
Acetate Solvents ●
Acetamide ●
Acetic Acid ●
Acetic Acid □
Acetic Acid - glacial ●
Acetic Anhydride ●
Acetone ●
Acetyl Chloride ●
Acetylene (Liquid Phase) ●
Acid Clay ●
Acrylic Acid ●
Acrylonitrile ●
Activated Alumina ●
Activated Carbon ●
Activated Silica ●
Alcohol-Allyl ●
Alcohol-Amyl ●
Alcohol-Benzyl ●
Alcohol-Butyl ●
Alcohol-Ethyl ●
Alcohol-Furfuryl ●
Alcohol-Hexyl ●
Alcohol-Isopropyl ●
Alcohol-Methyl ●
Alcohol-Propyl ●
Alum-Ammonium ●
Alum-Chrome ●
Alum-Potassium ●
Alum-Sodium ●
Alumina ●
Aluminum Acetate ●
Aluminum Bicarbonate ●
Aluminum Bifluoride ●
Aluminum Chloride ●
Aluminum Sulfate ●
Ammonia Anhydrous ■
Ammonia Solutions ■
Ammonium Bisulfite ●
Ammonium Borate ●
Ammonium Bromide ●
Ammonium Carbonate ●
Ammonium Chloride ●
Ammonium Chromate ●
Ammonium Fluoride ●
Ammonium Fluorosilicate ●
Ammonium Formate ●
Ammonium Hydroxide ■
Ammonium Hyposulfite ●
Ammonium Iodide ●
Ammonium Molybdate ●
Ammonium Nitrate ●
Ammonium Oxalate ●
Ammonium Persulfate ●
Ammonium Phosphate ●
Ammonium Picrate ●
Ammonium Sulfate ●

Ammonium Sulfate Scrubber ●
Ammonium Sulfide ●
Ammonium Thiocyanate ●
Amyl Acetate ●
Amyl Amine ●
Amyl Chloride ●
Aniline ●
Aniline Dyes ●
Anodizing Bath ●
Antichlor Solution ●
Antimony Acid Salts ●
Antimony Oxide ●
Antioxidant Gasoline ●
Aqua Regia ■
Argon ●
Armeen § ●
Arochlor § ●
Aromatic Gasoline ●
Aromatic Solvents ●
Arsenic Acid ●
Asbestos Slurry ●
Ash Slurry ●
Asphalt Emulsions ●
Asphalt Molten ●

Bagasse Fibers ●
Barium Acetate ●
Barium Carbonate ●
Barium Chloride ●
Barium Hydroxide □
Barium Sulfate ●
Battery Acid □
Battery Diffuser Juice ●
Bauxite (See Alumina) ●
Bentonite ●
Benzaldehyde ●
Benzene ●
Benzene Hexachloride ●
Benzene in Hydrochloric Acid ●
Benzoic Acid ●
Benzotriazole ●
Beryllium Sulfate ●
Bicarbonate Liquor ●
Bilge Lines ●
Bleach Liquor ●
Bleached Pulp ●
Borax § Liquors ●
Boric Acid ●
Brake Fluids ●
Brine Chlorinated ●
Brine Cold ●
Bromine Solution †
Butadiene ●
Butyl Acetate ●
Butyl Alcohol ●
Butyl Amine ●
Butyl Cellosolve § ●
Butyl Chloride ●
Butyl Ether - Dry ●
Butyl Lactate ●
Butyral Resin ●
Butyraldehyde ●
Butyric Acid □

Cadmium Chloride ●
Cadmium Plating Bath ●
Cadmium Sulfate ●
Calcium Acetate ●

Calcium Bisulfate ●
Calcium Carbonate ●
Calcium Chlorate ●
Calcium Chloride ●
Calcium Chloride Brine ●
Calcium Citrate ●
Calcium Ferrocyanide ●
Calcium Formate ●
Calcium Hydroxide ●
Calcium Lactate ●
Calcium Nitrate ●
Calcium Phosphate ●
Calcium Silicate ●
Calcium Sulfamate ●
Calcium Sulfate ●
Calcium Sulfite ●
Camphor ●
Carbitol ●
Carbolic Acid (phenol) □
Carbon Bisulfide ●
Carbon Black ●
Carbon Tetrachloride ●
Carbonic Acid □
Carbowax § ●
Carboxymethyl Cellulose ●
Carnauba Wax ●
Casein ●
Casein Water Paint ●
Celite ●
Cellosolve § ●
Cellulose Pulp ●
Cellulose Xanthate ●
Cement Dry/Air Blown ●
Cement Grout ●
Cement Slurry ●
Ceramic Enamel ●
Ceric Oxide ●
Chalk ●
Chemical Pulp ●
Chestnut Tanning ●
China Clay ●
Chloral Alcoholate ●
Chloramine ●
Chlorinated Hydrocarbons ●
Chlorinated Paperstock ●
Chlorinated Solvents ●
Chlorinated Sulphuric Acids ■
Chlorinated Wax ●
Chlorine Dioxide ■
Chlorine Liquid ■
Chlorine Dry ■
Chloroacetic Acid □
Chlorobenzene Dry ●
Chloroform Dry ●
Chloroformate Methyl ●
Chlorosulfonic Acid ■
Chrome Acid Cleaning □
Chrome Liquor □
Chrome Plating Bath □
Chromic Acid 10% ●
Chromic Acid 50% (cold) ■
Chromic Acid 50% (hot) ■
Chromium Acetate ●
Chromium Chloride ●
Chromium Sulfate ●
Classifier ●
Clay ●
Coal Slurry ●

Coal Tar ●
Cobalt Chloride ●
Copper Ammonium Formate ●
Copper Chloride ●
Copper Cyanide ●
Copper Liquor ●
Copper Naphthenate ●
Copper Plating, Acid Process ●
Copper Plating, Alk. Process ●
Copper Sulfate ●
Core Oil ●
Corundum ●
Creosote ●
Creosote-Cresylic Acid ●
Cyanide Solution ●
Cyanuric Chloride ●
Cyclohexane ●
Cylinder Oils ●

De-Ionized Water ●
De-Ionized Water Low Conductivity ●
Detergents ●
Developer, photographic ●
Dextrin ●
Diacetone Alcohol ●
Diammonium Phosphate ●
Diamylamine ●
Diatomaceous Earth Slurry ●
Diazo Acetate ●
Dibutyl Phthalate ●
Dichlorophenol ●
Dichloro Ethyl Ether ●
Dicyandamide ●
Dielectric Fluid ●
Diester Lubricants ●
Diethyl Ether Dry ●
Diethyl Sulfate ●
Diethylamine ●
Diethylene Glycol ●
Diglycolic Acid ●
Dimethyl Formamide ●
Dimethyl Sulfoxide ●
Dioxane Dry ●
Dioxidene ●
Dipentene - Pinene ●
Diphenyl ●
Distilled Water (Industrial) ●
Dowtherm § ●
Drying Oil ●
Dust-Flue (Dry) ●
Dye Liquors ●
Emery - Slurry ●
Emulsified Oils ●
Enamel Frit Slip ●
Esters General ●
Ethyl Acetate ●
Ethyl Alcohol ●
Ethyl Amine ●
Ethyl Bromide ●
Ethyl Cellosolve § ●
Ethyl Cellosolve Slurry § ●
Ethyl Formate ●
Ethyl Silicate ●
Ethylene Diamine ●
Ethylene Dibromide ●
Ethylene Dichloride ●
Ethylene Glycol ●

Ethylenediamine Tetramine ●

Fatty Acids ●
 Fatty Acids Amine ●
 Fatty Alcohol ●
 Ferric-Floc ●
 Ferric Chloride ●
 Ferric Nitrate ●
 Ferric Sulfate ●
 Ferrocence-Oil Sol ●
 Ferrous Chloride ●
 Ferrous Oxalate ●
 Ferrous Sulfate 10% ●
 Ferrous Sulfate (Sat) ●
 Fertilizer Sol ●
 Flotation Concentrates ●
 Fluoride Salts ●
 Fluorine, Gaseous or Liquid ●
 Fluorolube ●
 Fluosilic Acid ●
 Flux Soldering ●
 Fly Ash Dry ●
 Foam Latex Mix ●
 Foamite ●
 Formaldehyde (cold) ●
 Formaldehyde (hot) †
 Formic Acid (Dil cold) ●
 Formic Acid (Dil hot) †
 Formic Acid (cold) ●
 Formic Acid (hot) †
 Freon § †
 Fuel Oil ●
 Fuming Nitric Red ■
 Fuming Sulfuric ■
 Fuming Oleum ■
 Furfural ●

Gallic Acid * Gallium Sulfate ●
 Gasoline-Acid Wash ●
 Gasoline-Alk. Wash ●
 Gasoline Aviation ●
 Gasoline Copper Chloride ●
 Gasoline Ethyl ●
 Gasoline Motor ●
 Gasoline Sour ●
 Gasoline White ●
 Gluconic Acid ●
 Glue-Animal Gelatin ●
 Glue-Plywood ●
 Glutamic Acid ●
 Glycerine Lye-Brine ■
 Glycerol ●
 Glycine ●
 Glycine Hydrochloride ●
 Glycol Amine ●
 Glycolic Acid ●
 Glyoxal ●
 Gold Chloride ●
 Gold Cyanide ●
 Granodine ●
 Grape Pomace Graphite ●
 Grease Lubricating ●
 Green Soap ●
 Grinding Lubricant ●
 Grit Steel ●
 Gritty Water ●
 Greenwood Stock ●
 GRS Latex ●
 Gum Paste ●
 Gum Turpentine ●
 Gypsum ●

Halane Sol ●
 Halogen Tin Plating ●
 Halowax § ●
 Harvel-Trans Oil ●
 Heptane ●
 Hexachlorobenzene ●
 Hexadiene ●
 Hexamethylene Tetramine ●
 Hexane ●
 Hydrazine ●
 Hydrazine Hydrate ●
 Hydrobromic Acid □
 Hydrochloric Acid ●
 Hydrocyanic Acid □
 Hydroflouric Acid ■
 Hydrogen Peroxide (dil) ●
 Hydrogen Peroxide (con) †
 Hydroponic Sol ●
 Hydroquinone ●
 Hydroxyacetic Acid ●
 Hypo ●
 Hypochlorous Acid ●

Ink ●
 Ink in Solvent-Printing ●
 Iodine in Alcohol ●
 Iodine-Potassium Iodide ●
 Iodine Solutions ●
 Ion Exchange Service ●
 Ion Exclusion Glycol ●
 Irish Moss Slurry ●
 Iron Ore Taconite ●
 Iron Oxide ●
 Isobutyl Alcohol ●
 Isobutyraldehyde ●
 Isooctane ●
 Isopropyl Alcohol ●
 Isocyanate Resin ●
 Isopropyl Acetate ●
 Isopropyl Ether ●
 Itaconic Acid ●

Jet Fuels ●
 Jeweler's Rouge ●
 Jig Table Slurry ●
 Kaolin-China Clay § ●
 Kelp Slurry ●
 Kerosene ●
 Kerosene Chlorinated ●
 Ketone ●
 Lacquer Thinner ●
 Lactic Acid ●
 Lapping Compound ●
 Latex-Natural ●
 Latex-Synthetic ●
 Latex Synthetic Raw ●
 Laundry Wash Water ●
 Laundry Bleach ●
 Laundry Blue ●
 Laundry Soda ●
 Lead Arsenate ●
 Lead Oxide ●
 Lead Sulfate ●
 Lignin Extract ●
 Lime Slaked ●
 Lime Sulfur Mix ●
 Liquid Ion Exchange ●
 Lithium Chloride ●
 LOX (Liquid O2) ■

Ludox ●
 Lye ■

Machine Coating Color ●
 Magnesite Slurry ●
 Magnesite ●
 Magnesium Bisulfite ●
 Magnesium Carbonate ●
 Magnesium Chloride ●
 Magnesium Hydroxide ●
 Magnesium Sulfate ●
 Maleic Acid ●
 Maleic Anhydride ●
 Manganese Chloride ●
 Manganese Sulfate ●
 Melamine Resin ●
 Menthol ●
 Mercaptans ●
 Mercuric Chloride ●
 Mercuric Nitrate ●
 Mercury ●
 Mercury Dry ●
 Methane ●
 Methyl Alcohol ●
 Methyl Acetate ●
 Methyl Bromide ●
 Methyl Carbitol ●
 Methyl Cellosolve § ●
 Methyl Chloride ●
 Methyl Ethyl Ketone ●
 Methyl Isobutyl Ketone ●
 Methyl Lactate ●
 Methyl Orange ●
 Methylamine ●
 Methylene Chloride ●
 Mineral Spirits ●
 Mixed Acid, Nitric/Sulfuric ■
 Monochloroacetic Acid ●
 Morpholine ●
 Mud ●

Nalco Sol. ●
 Naphtha ●
 Naphthalene ●
 Naval Stores Solvent ●
 Nematocide ●
 Neoprene Emulsion ●
 Neoprene Latex ●
 Nickel Acetate ●
 Nickel Ammonium Sulfate ●
 Nickel Chloride ●
 Nickel Cyanide ●
 Nickel Fluoborate ●
 Nickel Ore Fines ●
 Nickel Plating Bright ●
 Nickel Sulfate ●
 Nicotinic Acid □
 Nitrate Sol. ●
 Nitration Acid(s) ■
 Nitric Acid ■
 Nitric Acid 10% □
 Nitric Acid 20% †
 Nitric Acid Anhydrous ■
 Nitric Acid Fuming ■
 Nitro Aryl Sulfonic Acid ●
 Nitrobenzene-Dry ●
 Nitrocellulose ●
 Nitrofurane ●
 Nitroguanidine ●
 Nitroparaffins-Dry ●
 Nitrosyl Chloride ●

Norite Carbon ●
 Nuchar ●

Oakite § Compound ●
 Oil, Creosote ●
 Oil, Emulsified ●
 Oil, Fuel ●
 Oil, Lubricating ●
 Oil, Soluble ●
 Oleic Acid, hot ●
 Oleic Acid, cold ●
 Ore Fines-Flotation ●
 Ore Pulp ●
 Organic Dyes ●
 Oxalic Acid cold ●
 Ozone, wet ■
 Paint-Flaxseed Base ●
 Paint-Water Base ●
 Paint-Remover-Sol. Type ●
 Paint-Vehicles ●
 Palmitic Acid ●
 Paper Board Mill Waste ●
 Paper Coating Slurry ●
 Paper Pulp ●
 Paper Pulp with Amun. ●
 Paper Pulp with Dye ●
 Paper Pulp, bleached ●
 Paper Pulp, bleached-washed ●
 Paper Pulp Chlorinated ●
 Paper Groundwood ●
 Paper Rag ●
 Paper Stocks, fine ●
 Paradichlorobenzene ●
 Paraffin Molten ●
 Paraffin Oil ●
 Paraformaldehyde ●
 Pectin Solution Acid ●
 Pentachlorethane ●
 Pentaerythritol Sol. ●
 Perchlorethylene (Dry) ●
 Perchloric Acid
 Perchloromethyl Mercaptan ●
 Permanganic Acid ■
 Persulfuric Acid ■
 Petroleum Ether ●
 Petroleum Jelly ●
 Phenol Formaldehyde Resins ●
 Phenol Sulfonic Acid ●
 Phenolic Glue ●
 Phloroglucinol ●
 Phosphate Ester ●
 Phosphatic Sand ●
 Phosphoric Acid 85% hot ■
 Phosphoric Acid 85% cold †
 Phosphoric Acid 50% hot †
 Phosphoric Acid 50% cold †
 Phosphoric Acid 10% cold ●
 Phosphoric Acid 10% hot †
 Phosphorous Molten ●
 Phosphotungstic Acid ●
 Photographic Sol. ●
 Phthalic Acid ●
 Phytate
 Phytate Salts ●
 Pickling Acid, Sulfuric ●
 Picric Acid Solutions ●
 Pine Oil Finish ●

Loctite product numbers in red are worldwide or application-specific products

(This is a list of chemical stability only. It does not constitute approval for use in the processing of food, drugs, cosmetics, pharmaceuticals, and ingestible chemicals.) Loctite products are not recommended for use in pure oxygen or chlorine environments or in conjunction with strong oxidizing agents.

LOCTITE

FLUID COMPATIBILITY CHART

for metal threaded fittings sealed with Loctite® Sealants

LIQUIDS, SOLUTIONS & SUSPENSIONS GASES

LEGEND:

● Use Loctite #592, 567, 565, 569, 545, 580, 571, 242, 577, 572, 542, 565, 545, 243
† Use Loctite #277, 271, 554, 270, 277, 554
■ Not Recommended
□ <10% (same as ●)
>10% (same as †)
* <5% (same as ●)
<5% (same as †)

Plating Sol. as follows:

Brass Cyanide ●
Bronze-Cyanide ●
Chromium & Cadmium Cyanide ●
Cobalt Acid ●
Copper Acid ●
Copper Alk. ●
Gold Cyanide ●
Iron-Acid ●
Lead-Fluoro ●
Nickel Bright ●
Platinum ●
Silver-Cyanide ●
Tin-Acid ●
Tin Alk. Barrel ●
Zinc Acid ●
Zinc Alk. Cyanide ●
Polyacrylonitrile Slurry ●
Polypentek ●
Polysulfide Liquor ●
Polyvinyl Acetate Slurry ●
Polyvinyl Chloride ●
Porcelain Frit ●
Potash □
Potassium Acetate ●
Potassium Alum. Sulfate ●
Potassium Bromide ●
Potassium Carbonate ●
Potassium Chlorate ●
Potassium Chloride Sol ●
Potassium Chromate ●
Potassium Cyanide Sol. ●
Potassium Dichromate ●
Potassium Ferricyanide ●
Potassium Hydroxide ■
Potassium Iodide ●
Potassium Nitrate ●
Potassium Perchlorate ●
Potassium Permanganate ●
Potassium Persulfate ●
Potassium Phosphate ●
Potassium Silicate ●
Potassium Sulfate ●
Potassium Xanthate ●
Press Board Waste ●
Propionic Acid ●
Propyl Alcohol ●
Propyl Bromide ●
Propylene Glycol ●
Pumice ●
Pyranol ●
Pyridine ●
Pyrogallic Acid ●
Pyrogen Free Water ●
Pyrole ●
Pyromellitic Acid ●

Quebracho Tannin ●
Rag Stock Bleached ●
Rare Earth Salts ●
Rayon Acid Water ●
Rayon Spin Bath ●
Rayon Spin Bath spent ●
Resorcinol ●
River Water ●
Road Oil ●
Roccal ●
Rosin-Wood ●
Rosin in Alcohol ●
Rosin Size ●
Rubber Latex ●
Safrol ●
Salt Alkaline ●
Salt Electrolytic ●
Salt Refrg. ●
Sand-Air Blown Slurry ●
Sand-Air Phosphatic ●
Sea Coal ●
Sea Water ●
Selenium Chloride ●
Sequestrene ●
Sewage ●
Shellac ●
Shower Water ●
Silica Gel ●
Silica Ground ●
Silicone Tetrachloride ●
Silicone Fluids ●
Silver Cyanide ●
Silver Iodide-Aqu. ●
Silver Nitrate ●
Size Emulsion ●
Skelly Solve E, L ●
Slate to 400 Mesh ●
Soap Lye ■
Soap Solutions (Stearates) ●
Soap Stone Air Blown ●
Soda Pulp ●
Sodium Acetate ●
Sodium Acid Fluoride ●
Sodium Aluminate ●
Sodium Arsenate ●
Sodium Benzene Sulfonate ●
Sodium Bichromate ●
Sodium Bisulfite ●
Sodium Bromide ●
Sodium Carbonate ●
Sodium Chlorate ●
Sodium Chlorite ●
Sodium Cyanide ●
Sodium Ferricyanide ●
Sodium Formate ●
Sodium Glutamate ●
Sodium Hydrogen Sulfate ●
Sodium Hydrosulfite ●
Sodium Hydrosulfide ●
Sodium Hydrochloride ●
Sodium Hydroxide ■
Sodium Hydro. 20% cold ●
Sodium Hydro. 20% hot †
Sodium Hydro. 50% cold †
Sodium Hydro. 50% hot ■

Sodium Hydro. 70% cold †
Sodium Hydro. 70% hot ■
Sodium Hypochlorite ●
Sodium Lignosulfonate ●
Sodium Metasilicate ●
Sodium Molten ●
Sodium Nitrate ●
Sodium Nitrite-Nitrate ●
Sodium Perborate ●
Sodium Peroxide ■
Sodium Persulfate ●
Sodium Phosphate-Mono ●
Sodium Phosphate-Tri ●
Sodium Potassium Chloride ●
Sodium Salicylate ●
Sodium Sesquicarbonate ●
Sodium Silicate ●
Sodium Silcofluoride ●
Sodium Stannate ●
Sodium Sulfate ●
Sodium Sulfide ●
Sodium Sulfite ●
Sodium Sulfhydrate ●
Sodium Thiocyanate ●
Sodium Thiosulfate ●
Sodium Tungstate ●
Sodium Xanthate ●
Solox-Denat. Ethanol ●
Soluble Oil ●
Solvent Naphthas ●
Sorbic Acid ●
Sour Gasoline ●
Soybean Sludge-Acid ●
Spensol Solution ●
Stannic Chloride ●
Starch ●
Starch Base ●
Steam Low Pressure ●
Stearic Acid ●
Steep Water ●
Sterilization Steam ●
Stillage Distillers ●
Stoddard Solvent ●
Styrene ●
Styrene Butadiene Latex ●
Sulfamic Acid ●
Sulfan-Sulfuric Anhydride ●
Sulfathiazole ●
Sulfite Liquor ●
Sulfite Stock ●
Sulfonated Oils ●
Sulfones ●
Sulfonic Acids ●
Sulfonyl Chloride ●
Sulfur Slurry ●
Sulfur Solution ●
in Carbon Disulfide ●
Sulphuric Acid 0-7% †
Sulphuric Acid 7-40% †
Sulphuric Acid 40-75% †
Sulphuric Acid 75-95% ■
Sulphuric Acid 95-100% ■
Sulphurous Acid †
Sulfuryl Chloride ●
Surfactants ●
Synthetic Latex ●
Taconite - Fines ●

Talc - Slurry ●
Tankage - Slurry ●
Tannic Acid (cold) †
Tamin ●
Tar & Tar Oil ●
Tartaric Acid ●
Television Chemicals ●
Tergitol \$ ●
Terpineol ●
Tetraethyl Lead ●
Tetrahydrofuran ●
Tetranitromethane ●
Textile Dyeing ●
Textile Finishing Oil ●
Textile Printing Oil ●
Thiocyanic Acid ●
Thioglycollic Acid ●
Thionyl Chloride ●
Thiophosphoryl Chloride ●
Thiourea ●
Thorium Nitrate ●
Thymol ●
Tin Tetrachloride ●
Tinning Sol. DuPont ●
Titania Paper Coating ●
Titanium Oxide Slurry ●
Titanium Oxy Sulfate ●
Titanium Sulfate ●
Titanium Tetrachloride ●
Toluol ●
Toluene ●
p-Toluene Sulfonic Acid †
Transil Oil ●
Trichloroacetic Acid ●
Trichlorethane 1,1,1 ●
Trichlorethylene ●
Trichlorethylene-Dry ●
Tricresyl Phosphate ●
Triethanolamine ●
Triethylene Glycol ●
Trioxane ●
Tungstic Acid ●
Turpentine ●
UCON \$ Lube ●
Udylite Bath-Nickel ●
Undecylenic Acid ●
Unichrome Sol. Alk. ●
Uranium Salts ●
Uranyl Nitrate ●
Uranyl Sulfate ●
Urea Ammonia Liquor ●
Vacuum to 100 Micron ●
Vacuum below 100 Micr. ●
Vacuum Oil ●
Vanadium Pentoxide ●
Slurry ●
Varnish ●
Varsol-Naphtha Solv. ●
Versene \$ ●
Vinyl Acetate Dry or Chloride Monomer ●
Vinyl Chloride Latex Emul. ●
Vinyl Resin Slurry ●
Viscose ●
Vortex-Hydroclone ●

Water-Acid - Below pH7 ●	Zinc Fines Slurry ●	Chlorine Dry ■	Isobutane ●
Water pH7 to 8 ●	Zinc Flux Paste ●	Chlorine Wet ■	Methane ●
Water Alkaline - Over pH8 ●	Zinc Galvanizing ●	Coke-oven Gas-cold ●	Methyl Chloride ●
Water Mine Water ●	Zinc Hydrosulfite ●	Coke-oven Gas-hot †	Natural gas dry ●
Water River ●	Zinc Oxide in Water ●	Cyanogen Chloride ●	Nitrogen gas ●
Water Sandy ●	Zinc Oxide in Oil ●	Cyanogen Gas ●	Nitrous Oxide ●
Water "White" - low pH ●	Zinc Sulfate ●	Ethane ●	Oil-Solvent Vapor ●
Water "White" - high pH ●	Zincolate ●	Ether-see Diethyl Ether ●	Oxygen ■
Wax ●	Zirconyl Nitrate ●	Ethylene ●	Ozone ■
Wax Chlorinated ●	Zirconyl Sulfate ●	Ethylene Oxide ●	Producer Gas 50 PSI ●
Wax Emulsions ●	Acetylene ●	Freon § (11-12-21-22) †	Propane ●
Weed Killer Dibromide ●	Acid & Alkali Vapours ●	Furnace Gas hot †	Propylene ●
Weisberg Sulfate Plating ●	Air ●	Furnace Gas cold ●	Steam ■
Wood ground pulp ●	Amine ●	Gas drip oil ●	Sulfur Dioxide ●
Wort Lines ●	Ammonia ●	Gas flue ●	Sulfur Dioxide dry ●
X-Ray Developing Bath ●	Butane ●	Gas manufacturing ●	Sulfur Trioxide Gas ■
Xylene ●	Butadiene Gas/Liquid ●	Gas natural ●	Sulfuric Acid Vapor ●
Zelan ●	Butylene Gas/Liquid ●	Helium ●	
Zeolite Water ●	By-Product Gas (Dry) ●	Hydrogen Gas-cold ●	
Zinc Acetate ●	Carbon Dioxide ●	Hydrogen Chloride ●	
Zinc Bromide ●	Carbon Disulfide ●	Hydrogen Cyanide ●	
Zinc Chloride ●	Carbon Monoxide ●	Hydrogen Sulfide wet & dry ●	
Zinc Cyanide-Alk. ●	Chloride Dry ●		

NOTE: 1. The above information does not constitute a recommendation of sealant use. It is intended only as a guide for consideration by the purchaser with the expectation of favorable confirming test results. It is impossible to test sealant reaction with the multitude of chemicals in existence, therefore, compatibility has been estimated based on a wide variety of customer experience.

2. With the stringent action of such chemicals as Freon, strong cold acids and caustics, thorough evaluation is suggested. Sealing of hot corrosive chemicals is not recommended.

3. Contact Loctite Corporation for use with chemicals not covered by this information.

§Listing(s) may be Brand Name(s) or Trademarks for chemicals of Corporations other than Loctite.

Loctite product numbers in red are worldwide or application-specific products.

(This is a list of chemical stability only. It does not constitute approval for use in the processing of foods, drugs, cosmetics, pharmaceuticals, and ingestible chemicals). Loctite products are not recommended for use in pure oxygen or chlorine environments or in conjunction with strong oxidizing agents.

The data contained herein are furnished for information only and are believed to be reliable. We cannot assume responsibility for the results obtained by others over whose methods we have no control. It is the user's responsibility to determine suitability for the user's purpose of any production methods mentioned herein and to adopt such precautions as may be advisable for the protection of property and of persons against any hazards that may be involved in the handling and use thereof.

In light of the foregoing, LOCTITE CORPORATION SPECIFICALLY DISCLAIMS ALL WARRANTIES OF MERCHANTABILITY OR FITNESS FOR A PARTICULAR PURPOSE ARISING FROM SALE OR USE OF LOCTITE CORPORATION'S PRODUCTS. LOCTITE CORPORATION SPECIFICALLY

DISCLAIMS ANY LIABILITY FOR CONSEQUENTIAL OR INCIDENTAL DAMAGES OF ANY KIND, INCLUDING LOST PROFITS. The discussion herein of various processes or compositions is not to be interpreted as a representation that they are free from domination of patents owned by others or as a license under any LOCTITE CORPORATION patents which may cover such processes or compositions. We recommend that each prospective user test the proposed application to determine its suitability for the purposes intended prior to incorporation to determine its suitability for manufacturing process using this data as a guide. This product may be covered by one or more United States or foreign patents or patent application.

LOCTITE
Loctite Americas

© 2000 Loctite Corporation 1001 Trout Brook Crossing, Rocky Hill, CT 06067 • Tel (860) 571-5700 • FAX (860) 571-5465

LT-836A (8/00) 0004-618

CHAPTER 6

808PSi INSTALLATION GUIDE

1. Pick a spot in the tank for the sender bar to be mounted. It should be as close to the middle of the tank as possible. Allow room for the head at the top of the sender bar. Make sure that the float will not contact any baffles or other obstructions in the tank. It is preferable if the float can be accessed from the hatch, to make any future service work easier. For this reason **do not** mount the float behind a baffle where it can't be reached from the hatch.
2. Drill or cut a hole in the top of the tank to mount a 1 inch NPT coupler (not provided). Weld the top coupler in place.
3. Slide the compression fitting over the sender bar, threads facing down, and insert the bar through the coupler and align it vertically in the tank. Determine how much length needs to be cut off the bottom of the bar. At a minimum the bar should be mounted 1 inch off the bottom of the tank to allow for tank expansion and contraction. For tanks greater than 75 inches in height, increase the gap to 1.5 inches. Cut the bar with a hack saw and trim exposed circuit board with a sharp knife. **Do not use a disk type cutoff saw since the heat generated will short circuit the internal circuit board.**
4. **Ensure that the compression fitting is on the bar** and clean the end of the bar and the inside of the end cap with Loctite 7070 Cleaner. Spray Loctite T7471 Primer onto both the end of the bar and the inside of the end cap. Allow the primer to dry for a few minutes. Apply a bead of Loctite 680 Retaining Compound around the bottom of the tube and around the top of the end cap. Place the cap onto the end of the tube with a twisting motion so that the retaining compound is smeared completely on the portion of the bar where the end cap is. To remove entrapped air, place the end on the floor and rock the bar until excess air has escaped. Keep the end cap in position by gently clamping the bar in a vise with the end against a solid object. Avoid setting the end cap against a cold floor, as this will slow the curing process. The curing time should be about an hour at room temperature. **The Loctite must be set before the tank is put into service. Bar failure due to a leaking end cap is NOT covered by warranty.** Note that a kit with all the required Loctite products is available from Garnet. For further details on the Loctite products see Technical Service Bulletin #17 on our web site, www.garnetinstruments.com.

- Make up an anchor by cutting a 4" X 16" piece of 1/4" thick material. Bend each end down at 90 degrees (see the diagram below), so the resulting flat piece is about 4" X 10" inches with 3" sides. Drill a hole to insert a 2" ID schedule 40 pipe in the center of the plate, weld tube to plate. Insert the bar into the tank and slide the anchor assembly over the sensor bar with the "U" facing down. Align the sensor bar vertically and weld the anchor in place to the bottom of the tank. Pull the sensor bar up a bit and slide the float (cone side up) over the bar. Lower the bar back into the anchor.

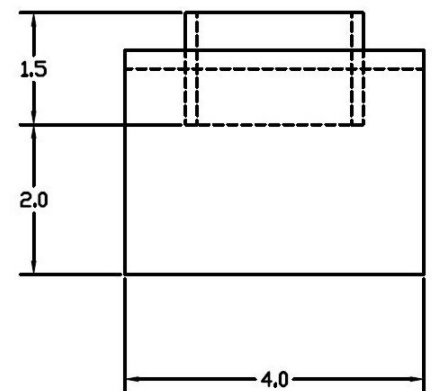
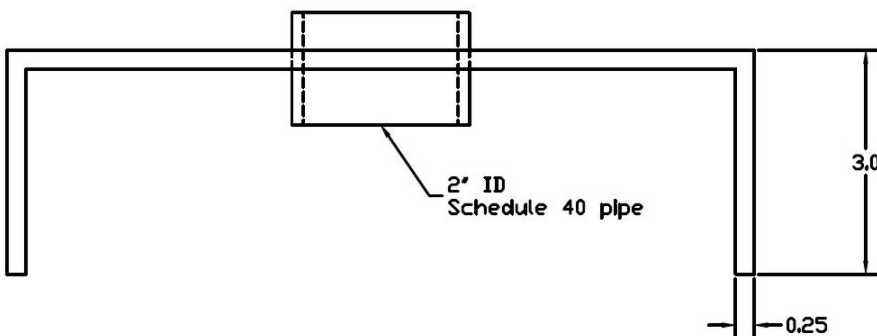
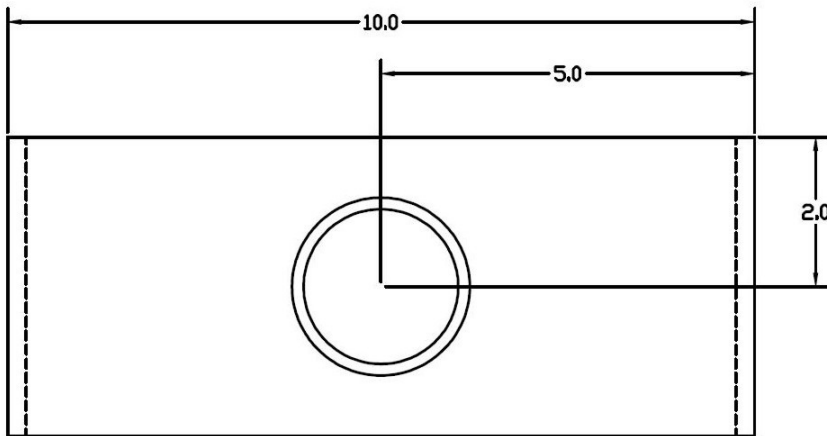

- Tighten the base of the compression fitting into the coupler. Lift the bar 2" off the bottom of the tank, and tighten down the compression fitting nut. Raise and lower the float a few inches to set the bottom reading.
- Pick a spot in the cab for the display. Make sure that the display is visible from the driver's seat and from the door. Make up a bracket to hold the box in position and mount the box, but leave the front panel off. The front panel is held on by the four small Phillips screws in the corners. **DO NOT** remove the two larger Robertson screws.

8. Route 1/4" Nylon air brake hose (Synflex) from the sensor head to the display and fasten with a **brass insert** and **compression fitting** at the head end. Drill holes in the back of the box (make sure the front panel is out) for the fiber and the two wires. **At the lowest point in the air line insert a T fitting with approximately two feet of Synflex hanging down to provide a drain for any water than may get into the system.** Locate the end of the Synflex near to the display box and feed the fiber optic cable through the hose, leaving about 12 inches extra at the head end. Route the fiber into the box through the hole that was drilled.
9. Cut the fiber ends square with a sharp knife and insert the fiber into the connectors at each end and tighten the connector lock nuts. Make sure that the fiber is loosely coiled inside the enclosure and is not pulled tight or bent sharp. The display should change from reading "no L" to some inch value as soon as the fiber is connected. If not, check that the fiber ends are clean and cut square, and that the fiber is fully inserted into the connectors at each end. If the display shows "bL: 8" or "bL:11" reprogram the sender bar or display for the correct mode (1/3 or 1/6 inch).
10. Inspect the head cap for casting flash, lightly sand or scrape off any casting protrusions. Make sure that there is grease on the rubber O-ring and snap on the head cap.
11. At the display, connect the **BLACK** ground wire to ground and the **RED** power wire to a 12 volt power source via a one amp fuse. The **WHITE** switch wire goes to the white wire on the switch, with the black switch wire going to ground. The **BLUE** switch wire connects to the blue wire on the switch, with the black switch wire going to ground. Only the power and ground wires must be connected to operate the display. If the serial number of your display begins with 808PSi RD then you have a Remote Display version. This version of the display only has the black, red and blue wires as described above. However it also has an additional **GREEN/YELLOW** wire from which it receives its data. This wire is connected to the corresponding green/yellow wire in a Model 810PS2 or Model 808P2 display which transmits the data. This wire is shown on the wiring diagram.
12. Program the gauge as directed in the programming section. The display must have power applied in order for programming to be accomplished. To determine the bottom reading of the gauge, measure from the bottom of

the tank to the middle of the straight vertical part of the float when the float is resting on the anchor. Do **NOT** set the gauge to read "0" at the bottom since this will not result in a correct reading when the float is actually floating on the product. In addition, if the gauge ever goes below "0" due to tank expansion, it will read some nonsensical value since this region has not been programmed.

13. Fasten on the front panel with the four Phillips screws in the corners. The screws are small, **do not** over tighten them. The screws are in soft plastic so they do not need to be really tight to keep from backing out. The two Robertson (square head) screws are used to attach the circuitry to the front panel and should not be removed.
14. Verify gauge operation by lifting the float. Record the unit number, calibration units, minimum and maximum readout values, and any alarm points programmed in the IMPORTANT OPERATOR INFORMATION area on the front page of the owner's manual.

CHAPTER 7

SENDER BAR PROGRAMMING

The 808PSi sender bar is identified by an “X” in the serial number, for example 810X-9999. It can be programmed for either 1/3” 8 bit operation or 1/6” 11 bit operation. The reason that the bar sends more bits for 1/6” operation is that there are twice as many points to send. The 808PSi display must be programmed to match the mode of the bar, so if the bar is in 1/3” mode the display must be in 1/3” mode, and if the bar is in 1/6” mode the display must be in 1/6” mode. If the modes do not match, the display will show bL: 8 or bL:11.

CAUTION: If the bar is being used with a display other than an 808PSi, contact your dealer or Garnet Instruments before attempting to operate the bar in 1/6” mode with the different display.

For security, the bar holds its mode information in three different memory locations and continually takes the best two out of three as being the correct mode. If any one location is corrupted it is automatically repaired. If the bar ever loses its mode information completely, it will default to 1/3” operation.

The bars are always shipped in 1/3” mode, so they only need to be programmed if the 1/6” mode is desired. If a bar is in 1/6” mode it can be programmed back to 1/3” mode. A bar can be reprogrammed any number of times. The bar mode is programmed by holding a magnet underneath the head for a specific period of time. The magnet can either be one you have, or a float can be used – slide it right up against the head (this can only be done before the compression fitting is on). The magnet is in the correct position when the opto appears to flicker continuously instead of flashing.

To program a bar to 1/6” mode, hold the magnet under the head for 12 seconds. The LED should appear to flicker continually during this time. Remove the magnet after the 12 seconds, the LED will respond with 6 long flashes (1 second on, 1 second off, 1 second on, etc.). After the 6 long flashes, the bar will resume normal operation. If desired, the bar can be plugged into the 817 **OPTICAL INPUT**, the # BITS should show 11. Note that the timing window is from 9 to 15 seconds, so you don’t have to be exact.

To program a bar to 1/3” mode, hold the magnet under the head for 6 seconds. The LED should appear to flicker continually during this time. Remove the magnet after the 6 seconds, the LED will respond with 3 long

flashes (1 second on, 1 second off, 1 second on, etc.). After the 3 long flashes, the bar will resume normal operation. If desired, the bar can be plugged into the 817 **OPTICAL INPUT**, the # BITS should show 8. Note that the timing window is from 3 to 9 seconds, so you don't have to be exact.

If the magnet is held in position for less than 3 seconds or more than 15 seconds, the bar mode will not change. The bar can be programmed to either mode regardless of the mode it is currently in, so if in doubt about the mode feel free to reprogram.

CHAPTER 8

808PSi PROGRAMMING INSTRUCTIONS

The 808PSi provides an interactive programming experience. When the programming plug is connected to the gauge, the gauge display will show “prog” within a couple of seconds. Do not start programming the gauge until “prog” is shown. After the plug has been removed, the gauge display will show “donE” for a moment. Power must be applied to the display before any programming can be done and before the programmer is plugged in to the display.

Note: It is not possible to directly copy the calibration from an 808, 808i, 808A or old style 810 to an 808PSi. The calibration will have to be re-entered using the procedure to calibrate a gauge from a table of calibration values.

Program the 808PSi for the correct mode (1/3”, 1/4”, or 1/6”):

1. The 808PSi display can be used with the 808, 810, or 908 bars, which requires the installer to make sure that the display is programmed for the correct mode so that it will operate correctly with the sender bar used.
2. The 817 Truck Gauge Programmer is not needed for this operation. Only a magnet is required to change the mode.
3. Disconnect the fiber from the display and make sure that no ambient light is getting into the optical connector. The display must be showing “no L” in order to set the mode.
4. Hold the magnet next to the glass bodied reed switch on the back of the display face.
5. The display will show “C1-3”, “C1-4” or “C1-6” within a couple of seconds, indicating the current mode that the display is set for (the “C” means “current”). Continue to hold the magnet by the face.
6. After 3 seconds of showing the current mode, the display will show “P1-3” for 3 seconds, then it will show “P1-6” for three seconds, then it will show “P1-4” for three seconds (the “P” means “program”). Removing the magnet during the time that “P1-3” is shown will program the mode at 1/3”, removing the magnet during the time that “P1-6” is shown will program the mode at 1/6”, and removing the magnet during the time that “P1-4” is shown will program the mode at 1/4”. To confirm that the new mode has been stored in memory, the display will show “Stor” for one second after removing the magnet. (Some early models may not show the P1-4 mode; in this case use the P1-6 mode if a 1/4” resolution bar is being used).
7. If the magnet is held past the setting time for the 1/4” mode, the display will exit the mode setting program. Continuing to hold the magnet in place will

cause the display to re-enter the mode setting program from the beginning. Removing the magnet at any time other than when “P1-X” is shown will result in no change to the mode.

8. Double check the mode by holding the magnet in place until “C1-X” is shown, and then immediately remove the magnet.

Program the 808PSi gauge display into inches:

1. Press the **Power On & Reset** button to turn on the programmer.
2. Press for one second the **810P-1/3”** or **810P-1/6”** button to set the mode.
3. Select a memory location with **MEM LOC**.
4. Press for one second the **INCH MEM** button to put inches into the memory. (the Calibration Display will show “Inch”) If the inches are already in memory from a previous calibration, it is not necessary to do it again, but make sure that they are the correct inches (1/3 or 1/6).
5. Make sure that the fiber from the sender bar is connected to the gauge display, and plug the small programmer plug into the gauge display. Press the **BAR** button. The inch display should show some inch reading, if it shows “no L” or “bd L’ check the fiber connection and the bar mode (1/3 or 1/6 inch). NOTE: The black fiber optic cable connector MUST be shaded from direct sunlight. See the information in the General Notes section for further information.
6. Measure the distance from the bottom of the tank to the middle of the float, this is the bottom reading. Use the **OFFSET** buttons to obtain this reading on the Calibration Display.
7. Press for one second the **PROG** button (the Calibration Display will show “prog”).
8. When “prog” is done, unplug the programmer from the gauge and verify gauge operation.

Copy one 808PSi gauge display to another (can also copy from an 808P2 or 810PS/810PS2):

1. Press the **Power On & Reset** button to turn on the programmer.
2. Press for one second the **810P-1/3”** or **810P-1/6”** button to set the mode.
3. Select a memory location with **MEM LOC**.
4. Plug the small programmer plug into the gauge display to be copied **from**. Press for one second the **COPY** button to copy the gauge calibration into memory. (the calibration display will show “copy”)

5. When “copy” is done, unplug the programmer plug from the first gauge and plug it into the gauge display to be copied *to*. Press for one second the **PROG** button (the calibration display will show “prog”).
6. When “prog” is done, unplug the programmer from the gauge and verify gauge operation.

Program an 808PSi gauge display from a table of calibration values:

1. Obtain a table of inches versus volume
2. Press the **Power On & Reset** button to turn on the programmer.
3. Press for one second the **810P-1/3**” or **810P-1/6**” button to set the mode.
4. Select a memory location with **MEM LOC**.
5. Press for one second the **CLR MEM** button to erase any previous calibration. (the calibration display will show “CLr”)
6. Use the buttons on the middle keypad to enter the desired calibration. Press the **ENTR** button to store the value in memory. When **ENTR** is pressed, the inches will go to the next value. If you make a mistake, press **ENTR**, then **INCH ↓**, then re-enter the correct value, or just continue to enter the correct numbers, the previous ones will scroll off the left of the display (you will need to enter leading blanks if less than 4 digits are entered). If the current point is the same as the last one, simply press **ENTR** again to store the same calibration value as the last point.
7. After the table has been entered, use the **INCH** buttons to review the table to make sure it is correct. If a calibration value is incorrect, simply re-enter it and press **ENTR**.
8. Make sure that the fiber from the sender bar is connected to the gauge display, and plug the small programmer plug into the gauge display. Press the **BAR** button. The inch display should show some inch reading, if it shows “no L” or “bd L’ check the fiber connection and the bar mode (1/3 or 1/6 inch). NOTE: The black fiber optic cable connector MUST be shaded from direct sunlight. See the information in the General Notes section for further information.
9. Measure the distance from the bottom of the tank to the middle of the float; then look up this value in the calibration table to obtain the correct volume for the bottom reading. Use the **OFFSET** buttons to obtain this reading on the Calibration Display.
10. Press for one second the **PROG** button (the Calibration Display will show “prog”).
11. When “prog” is done, unplug the programmer from the gauge and verify gauge operation.

Program an 808PSi gauge display from a table stored in memory:

1. Press the **Power On & Reset** button to turn on the programmer.
2. Press for one second the **810P-1/3"** or **810P-1/6"** button to set the mode.
3. Select the correct memory location with **MEM LOC**.
4. Use the **INCH** buttons to review the table to make sure it is correct. If a calibration value is incorrect, simply re-enter it and press **ENTR**.
5. Make sure that the fiber from the sender bar is connected to the gauge display, and plug the small programmer plug into the gauge display. Press the **BAR** button. The inch display should show some inch reading, if it shows "no L" or "bd L" check the fiber connection and the bar mode (1/3 or 1/6 inch). NOTE: The black fiber optic cable connector MUST be shaded from direct sunlight. See the information in the General Notes section for further information.
6. Measure the distance from the bottom of the tank to the middle of the float; then look up this value in the calibration table to obtain the correct volume for the bottom reading. Use the **OFFSET** buttons to obtain this reading on the Calibration Display.
7. Press for one second the **PROG** button (the Calibration Display will show "prog").
8. When "prog" is done, unplug the programmer from the gauge and verify gauge operation.

Program an 808PSi gauge display for a tank with straight vertical sides:

1. If the tank has a constant cross section so that the volume increases linearly with depth, the programmer can calculate the calibration points so that only one value needs to be entered. Examples of these types of tanks would be upright cylindrical tanks (NOT on their side) and rectangular tanks.
2. Determine the gauge increment, that is, the resolution of the gauge. This will be 1/3" for a low resolution truck gauge or 1/6" for a high resolution truck gauge.
3. Calculate the tank volume for the gauge increment. This is done by calculating the area of the tank and multiplying by the gauge increment. The area will be $3.14159 \times \text{radius} \times \text{radius}$ for an upright cylindrical tank, or $\text{length} \times \text{width}$ for a rectangular tank. For example, for a 12 foot diameter tank with a high resolution truck gauge: radius = 6 feet = 182.88 cm, so the area is 105,070.86 square cm. 1/6" of depth is 0.4233 cm, so the volume per increment is 44,480 cubic cm, which is 0.04 480 cubic metres. (1 inch=2.54 cm, 1,000,000 cubic cm= 1 cubic meter)

4. Determine how many decimal places are to be displayed. For example, if the tank capacity is 22 cubic metres, two decimals could be displayed since there are four digits available. The user may only want one decimal, so it is best to check with the customer.
5. The number calculated in step 3 consists of two parts: the display digits and the guard digits. The display digits are the ones which will be shown, in our example with two decimal places the display digits will be 00.04 so the display will increase by 0.04 per increment. The guard digits are the next three digits which prevent round off error when the programmer calculates the calibration. In our example they would be 480. (if one decimal place were to be used, display digits would be 000.0 and the guard digits would be 448)
6. Press the **Power On & Reset** button to turn on the programmer.
7. Press for one second the **810P-1/3"** or **810P-1/6"** button to set the mode.
8. Select a memory location with **MEM LOC**.
9. Use the buttons on the middle keypad to enter the increment, guard digits first. In our example, press **4 8 0 0 0 . 0 4** which is the three guard digits followed by the four display digits. It is very important to enter all four digits for the display digits, even if some are zeros.
10. Press the **INCR** button for one second, the calibration display will show Incr while the programmer calculates all the points.
11. When the points have been calculated, the inch display will be at zero and the calibration display will show the display increment, in our example **.04** will be shown. A volume of zero is not shown due to the way that the programmer calculates the calibration.
12. Make sure that the fiber from the sender bar is connected to the gauge display, and plug the small programmer plug into the gauge display. Press the **BAR** button. The inch display should show some inch reading, if it shows "no L" or "bd L" check the fiber connection and the bar mode (1/3 or 1/6 inch). NOTE: The black fiber optic cable connector MUST be shaded from direct sunlight. See the information in the General Notes section for further information.
13. Measure the distance from the bottom of the tank to the middle of the float, then calculate the correct volume for the bottom reading (distance X volume increment / gauge increment, for our example if the distance was 4 inches, it would be $4 \times 0.04480 / 1/6 = 1.06$ cubic metres). Use the **OFFSET** buttons to obtain this reading on the Calibration Display.
14. Press for one second the **PROG** button (the Calibration Display will show "prog").
15. When "prog" is done, unplug the programmer from the gauge and verify gauge operation.

CHAPTER 9

TROUBLESHOOTING GUIDE

There are only 4 serviceable components in the gauge: the float, the sender bar, the interconnecting fiber optic cable, and the display.

If the float is sunk, the display will read the bottom tank reading all the time. If the float is partially sunk, the reading may rise and then fall as the tank is filled. If the float has lost its magnets, the reading on the display will stay the same as the fluid level changes, or the reading may appear to stick at one value then suddenly jump to a much different value.

If the fiber is damaged or the sender bar is dead, the display will read "no L" on the display. If the light level is poor due to a damaged or excessively bent fiber, or if the fiber is not fully inserted, or if the display is not programmed for the same resolution as the sender, the display will show "bL:xx", where xx is the number of bits being received. If the fiber optic cable is disconnected from the display, a flashing red light should be visible from the end of the fiber.

If the display reads erratically, check for water inside the head or display, and for a poor end cap seal. If no problem can be seen, the display will require factory servicing.

To test a sender bar:

1. Make sure the sender is flashing about once a second from the optical connector. If it is not, the sender is dead and must be replaced.
2. If the sender is flashing, plug a piece of fiber into the sender optical connector and the other end of the fiber into the **OPTICAL INPUT** on the 817 Truck Gauge Programmer. The top left display shows the number of bits the bar is sending and the optical power. If the optical power is poor (less than 70), then check the fiber, if it is good and fully inserted then the bar output is defective and the bar must be replaced. Ensure that the number of bits is correct (1/3" is 8 bits and 1/6" is 11 bits). If necessary reprogram the bar with a magnet (see the bar programming section) to put it into the correct mode. If the number of bits is not 8 or 11 then the bar is defective and must be replaced.
3. Press and hold for one second the appropriate mode button on the programmer to match the mode of the bar (**810PS 1/3"** or **810PS 1/6"**). Now press and hold for one second the **BAR TEST** button to put the programmer into the bar test mode. The inch display will now show what

the bar is putting out. Slowly run a float up the bar while watching the inch display to verify bar operation. If the bar does not operate correctly then it must be replaced. Note that it is faster to test the bar in 1/3" resolution, if it works for 1/3" it will work for 1/6". To return the programmer to normal operation press the **Power On & Reset** button.

4. If a programmer is not available, a quick test can be made of the bar by jumpering the two top pins on the programming plug in the display. This converts the display into reading raw inches only, the calibration is ignored. Run the float up and down on the bar to see if the inches change in a consistent manner. The bar should read around 80 to 85 inches when the float is near the top. The bottom reading will vary depending on the length of the bar.

Note: If the programmer or display is being used to test a bar outside in bright sunlight, the sunlight may penetrate right through the black **OPTICAL INPUT** housing and overwhelm the optical input. If this happens the programmer will appear to not respond to pressing the **BAR** or **BAR TEST** button. It will be necessary to shade the connector with your hand to ensure proper operation.

To test a display:

1. The display should show "no L" with no fiber connected. Note that if the optical connector on the display is exposed to ambient light the display may read "bd xx" (with xx being some number) or "Sun". If neither of these is the case then the display is defective and must be replaced. Note that it is possible for the display to "hang up" and freeze its display if it is exposed to excessive static shock or strong radio signals. If this is the case it should automatically reset itself within a few seconds.
2. Press the appropriate mode button to match what the display should be. Plug a piece of fiber from the **OPTICAL OUTPUT** of the 817 Truck Gauge Programmer to the optical connector on the display. If the display shows "no L" then it is defective and must be replaced (make sure the end of the fiber going into the display is flashing!). If the display shows "bd 8" or "bd 11" then it may be in the wrong mode. Reprogram the mode according to the instructions in the programming section. If it does not respond then it is defective and must be replaced.
3. If the display shows some strange reading when the fiber is plugged in, it may need reprogramming. Copy the existing programming into an unused memory on the 817 (just in case) and then program the display in inches or a known good program. The display should show "prog" within a couple of seconds of plugging in the 817 plug, if not it is defective. After the 817 plug

is removed the display should match the reading on the 817 calibration display, if it does not then the display is defective.

4. If only the alarms do not work then copy the calibration into the 817 to check if the points are programmed. If they are then connect a fiber from the 817 **OPTICAL OUTPUT** to the display optical connector. Connect the positive terminal of an ohm meter to the alarm wire, and the negative terminal of the ohm meter to the ground (green) wire. Use the inch up/down buttons on the 817 to run the display up to test the alarms. If the purple wire is being tested then make sure that both A3 and A4 are correctly programmed and run the display from below A3 to make sure that previous bypassing is cleared.

SEELEVEL TRUCK GAUGE BLOCK DIAGRAM

There are five basic parts to the system,

- 1) The Float
- 2) The Sender Bar
- 3) The Fiber Optic Cable
- 4) The Display
- 5) The Night Display

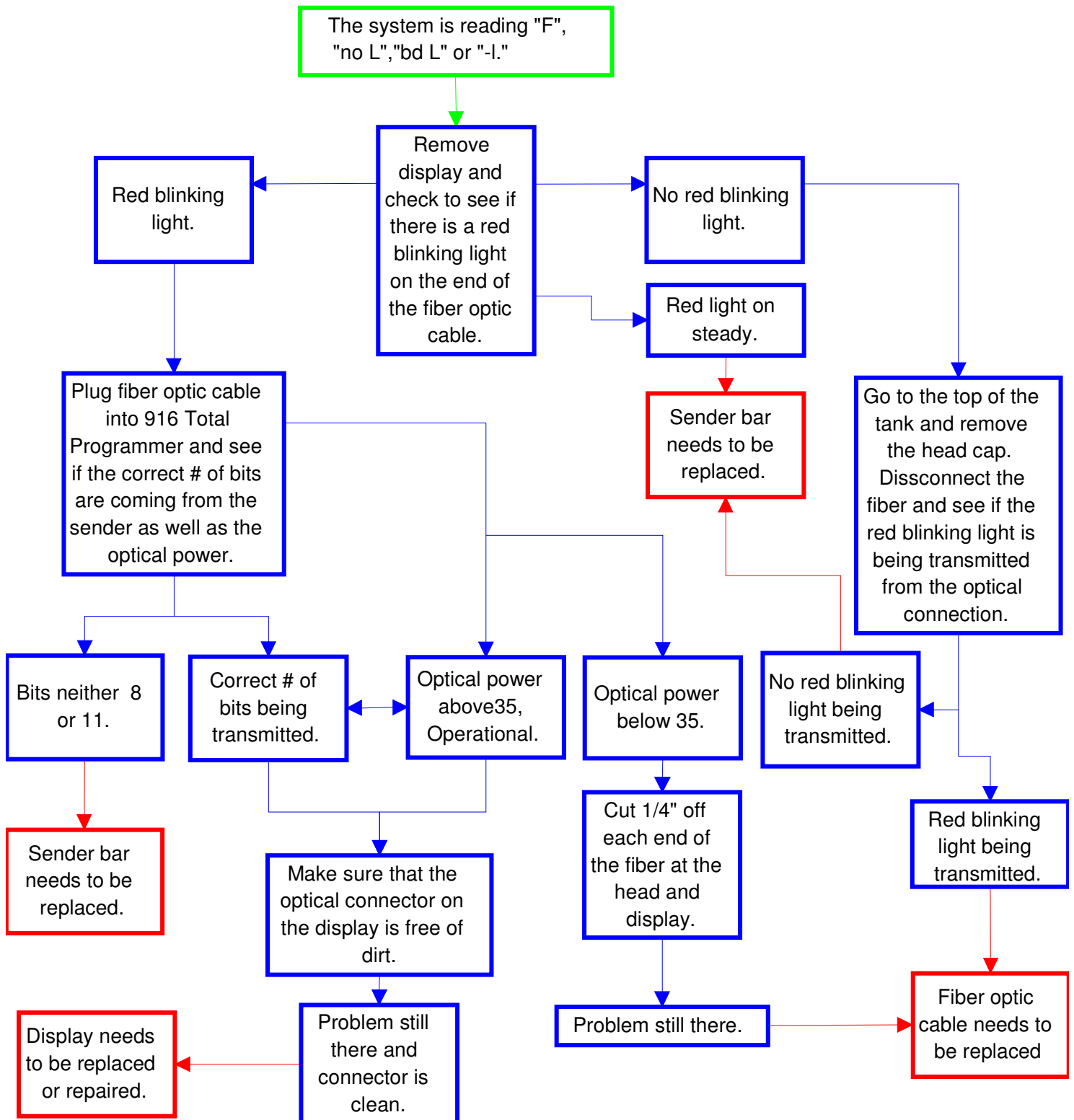

SEELVEL TRUCK GAUGE BLOCK DIAGRAM

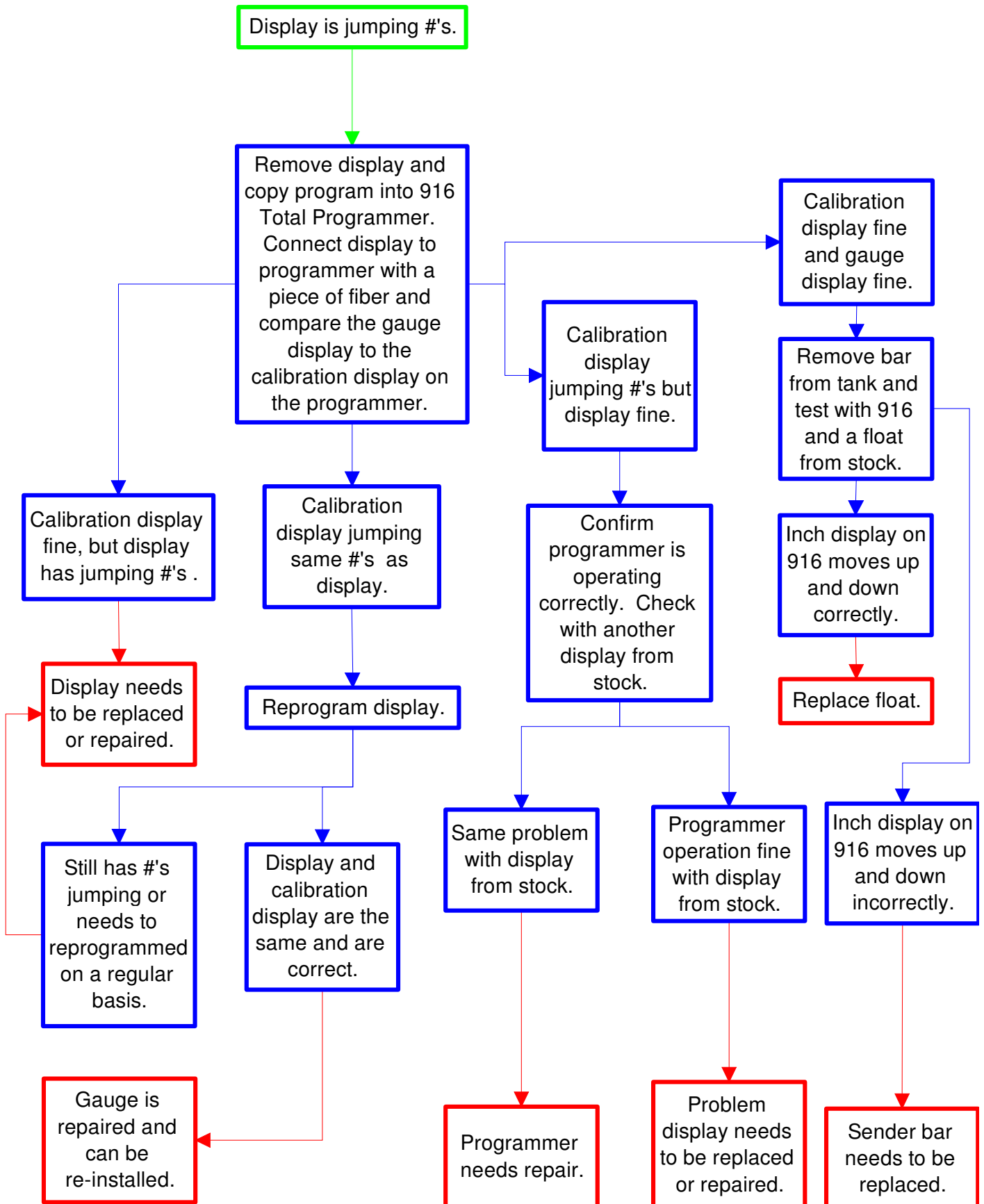

SEELLEVEL TRUCK GAUGE BLOCK DIAGRAM

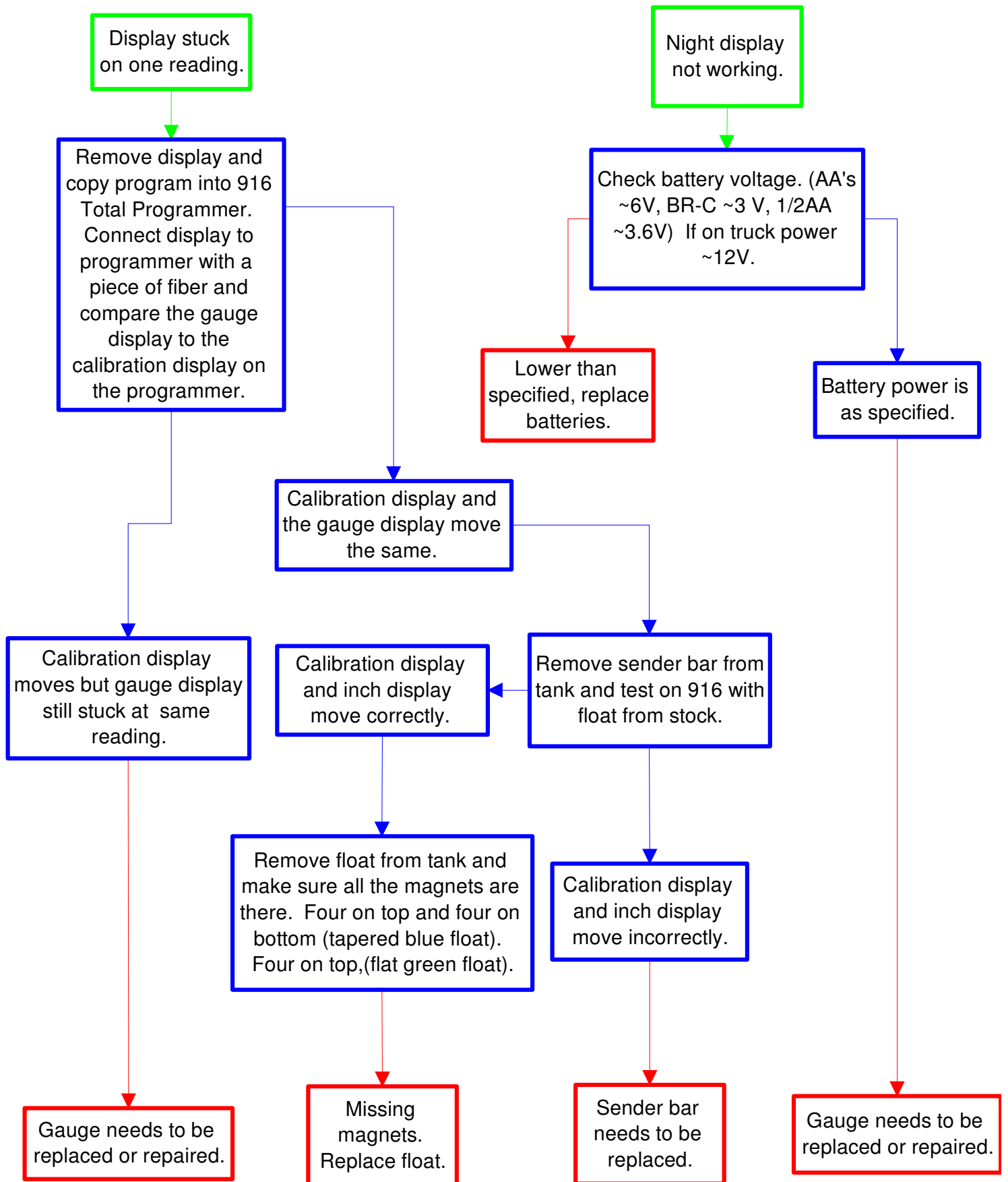

CHAPTER 10

SERVICE AND WARRANTY INFORMATION

The warranty will apply only if the warranty card shipped with the equipment has been returned to Garnet Instruments Ltd.

Garnet Instruments Ltd. warrants equipment manufactured by Garnet to be free from defects in material and workmanship under normal use and service for a period of one year from the date of sale from Garnet or an Authorized Dealer. The warranty period will start from the date of purchase or installation as indicated on the warranty card. Under these warranties, Garnet shall be responsible only for actual loss or damage suffered and then only to the extent of Garnet's invoiced price of the product. Garnet shall not be liable in any case for labor charges for indirect, special, or consequential damages. Garnet shall not be liable in any case for the removal and/or reinstallation of defective Garnet equipment. These warranties shall not apply to any defects or other damages to any Garnet equipment that has been altered or tampered with by anyone other than Garnet factory representatives. In all cases, Garnet will warrant only Garnet products which are being used for applications acceptable to Garnet and within the technical specifications of the particular product. In addition, Garnet will warrant only those products which have been installed and maintained according to Garnet factory specifications.

LIMITATION ON WARRANTIES

These warranties are the only warranties, expressed or implied, upon which products are sold by Garnet and Garnet makes no warranty of merchantability or fitness for any particular purpose in respect to the products sold. Garnet products or parts thereof assumed to be defective by the purchaser within the stipulated warranty period should be returned to the seller, local distributor, or directly to Garnet for evaluation and service. Whenever direct factory evaluation, service or replacement is necessary, the customer must first, by either letter or phone, obtain a Returned Material Authorization (RMA) from Garnet Instruments directly. No material may be returned to Garnet without an RMA number assigned to it or without proper factory authorization. Any returns must be returned freight prepaid to: Garnet Instruments Ltd, 286 Kaska Road, Sherwood Park, Alberta, T8A 4G7. Returned warranted items will be repaired or replaced at the discretion of Garnet Instruments. Any Garnet items under the Garnet Warranty Policy that are deemed irreparable by Garnet Instruments will be replaced at no charge or a credit will be issued for that item subject to the customer's request.

If you do have a warranty claim or if the equipment needs to be serviced, contact the installation dealer. If you do need to contact Garnet, we can be reached as follows:

Garnet Instruments Ltd.
286 Kaska Road
Sherwood Park, Alberta
Canada T8A 4G7
E-mail: tstalker@garnetinstruments.com

