

SEELEVEL II™

709-2P Wiring Diagram

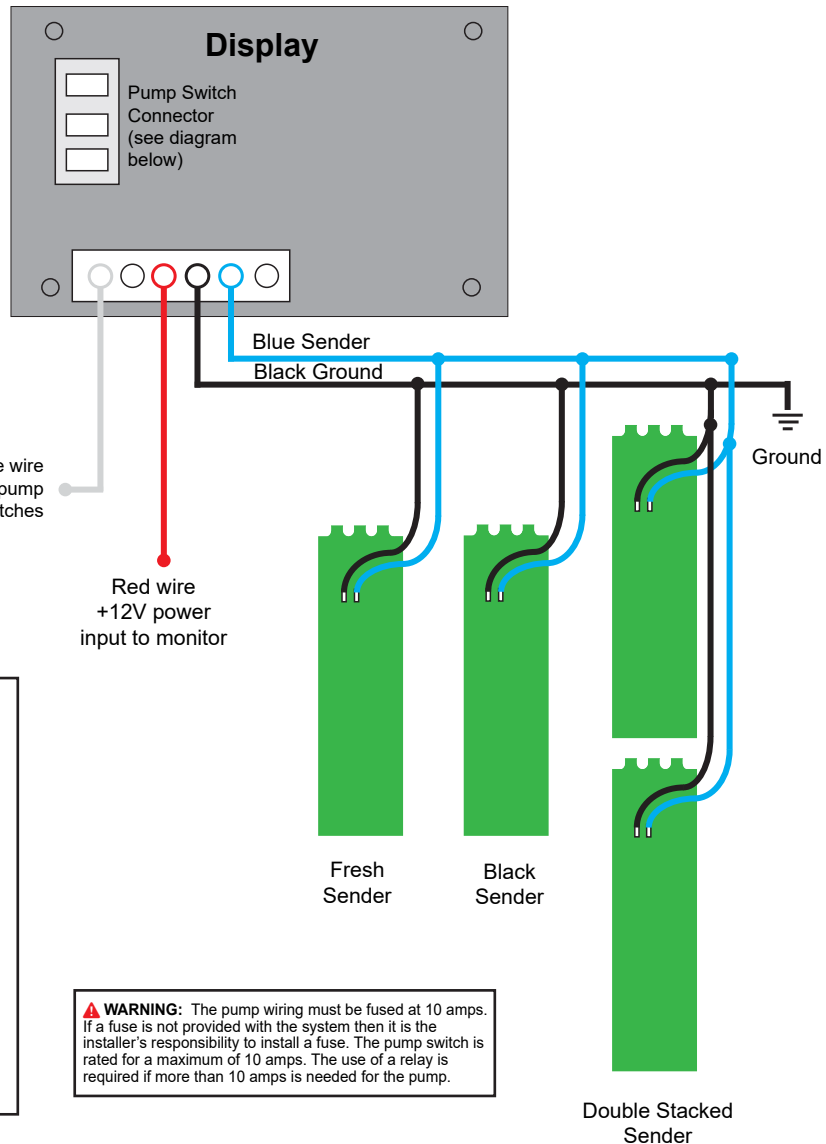

Pigtail Wires

Pin	Color	Function
1	White	Pump LED -
2	-	
3	Red	+12V
4	Black	Ground
5	Blue	Tank Senders
6	-	

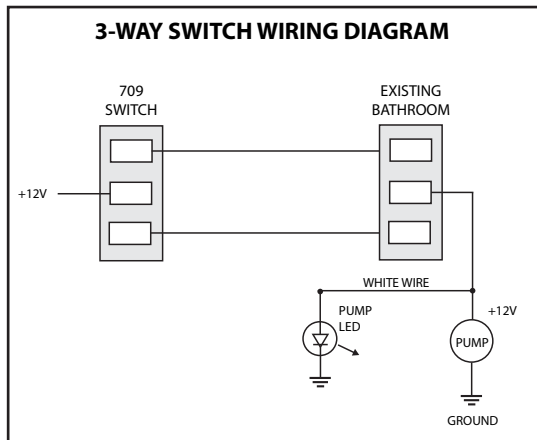

⚠ WARNING: The pump wiring must be fused at 10 amps. If a fuse is not provided with the system then it is the installer's responsibility to install a fuse. The pump switch is rated for a maximum of 10 amps. The use of a relay is required if more than 10 amps is needed for the pump.