

SEELLEVEL II™

709-4P Wiring Diagram

Pigtail Wires

Pin	Color	Function
1	-	-
2	-	-
3	Yellow	Pump Power Output
4	Red	+12V
5	Black	Ground
6	Blue	Tank Senders
7	-	-

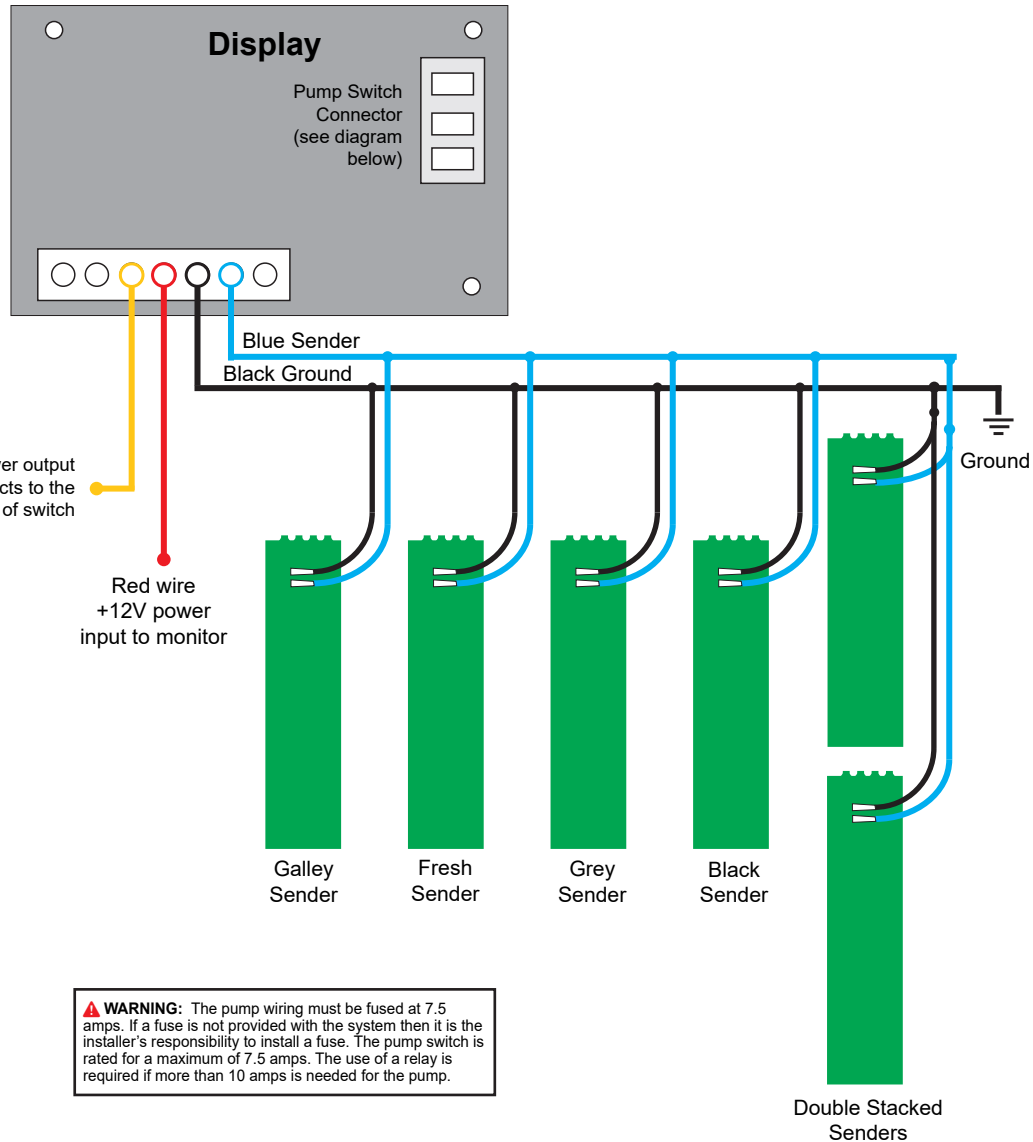
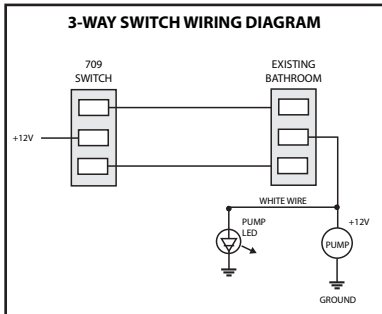

⚠ WARNING: The pump wiring must be fused at 7.5 amps. If a fuse is not provided with the system then it is the installer's responsibility to install a fuse. The pump switch is rated for a maximum of 7.5 amps. The use of a relay is required if more than 10 amps is needed for the pump.