

SEELEVEL II™

709-BTP7 Wiring Diagram

Common Alarm Output

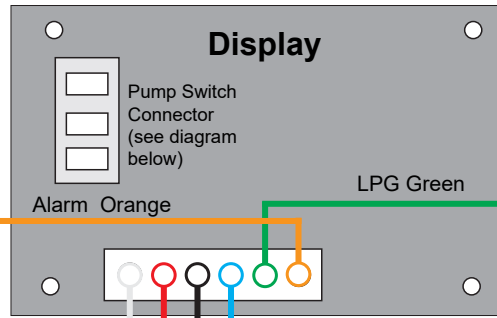

LPG Tank
Does not sense LPG only. LPG connects to the existing sensor. Only relay the signal from the sensor that's already installed.

Pigtail Wires

Pin	Color	Function
1	White	Pump LED
2	Red	+12V
3	Black	Ground
4	Blue	Tank Senders
5	Green	LPG Tank
6	Orange	Common Alarm Output

Pump LED white wire connects to the pump side of all switches

Red wire +12V power input to monitor

Monitors up to 7 Tanks

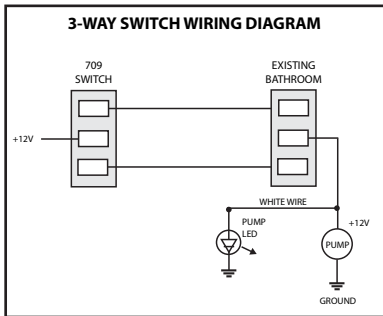

WARNING: The pump wiring must be fused at 10 amps. If a fuse is not provided with the system then it is the installer's responsibility to install a fuse. The pump switch is rated for a maximum of 10 amps. The use of a relay is required if more than 10 amps is needed for the pump.

WARNING: If the common alarm device exceeds the maximum rating of 1 amp a relay should be used.

Double Stacked Senders