

SEELEVEL II™

709-HP3W Wiring Diagram

Pigtail A Wires

Pin	Color	Function
1	-	-
2	White	Pump LED
3	Blue/white	Heater Indicator
4	Red	+12V
5	Black	Ground
6	Blue	Tank Senders
7	Green	LPG Tank

Pigtail B Wires

Pin	Color	Function
1	Yellow	3-way Term 1
2	Purple	3-way Common
3	Orange	3-way Term 2
4	-	-
5	Green/Yellow	Heater out
6	Grey	Heater In

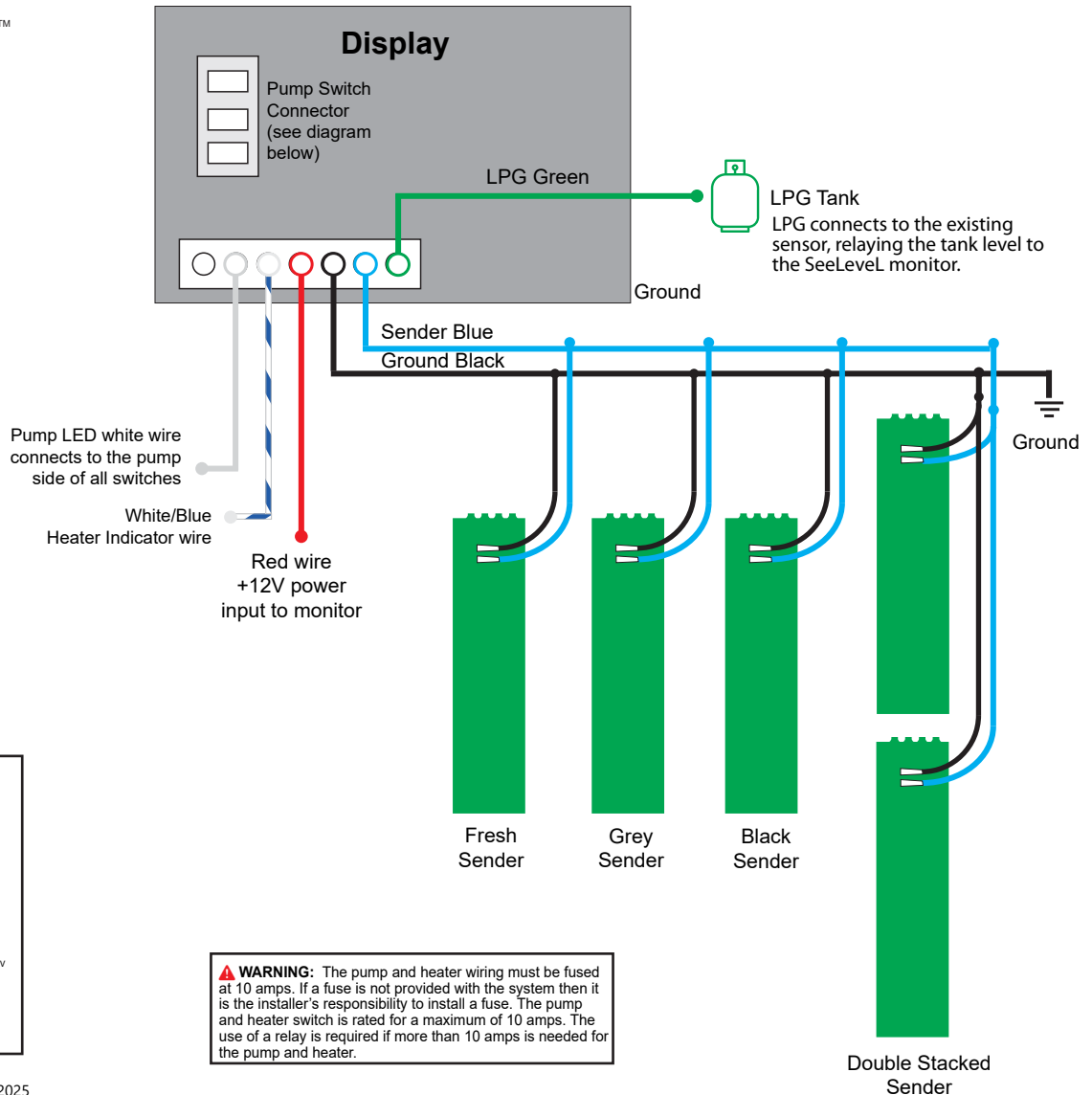
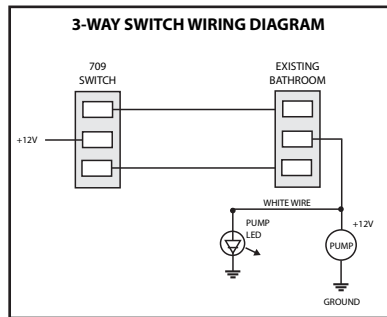

⚠ WARNING: The pump and heater wiring must be fused at 10 amps. If a fuse is not provided with the system then it is the installer's responsibility to install a fuse. The pump and heater switch is rated for a maximum of 10 amps. The use of a relay is required if more than 10 amps is needed for the pump and heater.