

# SEELEVEL ANNIHILATOR™

## Tank Truck Level Gauge



## MODEL 806-B / 806-Bi MANUAL

Includes firmware versions 2.03 and 2.04 information

Printed in Canada

**CANADA**  
Garnet Instruments Ltd.  
286 Kaska Road  
Sherwood Park, AB T8A 4G7

**USA**  
Garnet US Inc.  
5360 Old Granbury Road  
Granbury, TX 76049

# GARNET

Liquid management solutions, your way.

[garnetinstruments.com](http://garnetinstruments.com)  
1-800-617-7384

# **GARNET**

## **SEELVEL ANNIHILATOR™**

### Tank Truck Level Gauge

**MODEL 806-B / 806-Bi**

**Includes firmware versions 2.03 and 2.04 information**

## **Table of Contents**

CHAPTER 1 - OVERVIEW.....	3
CHAPTER 2 - NEW FEATURES OF THE ANNIHILATOR.....	4
CHAPTER 3 - GAUGE DESCRIPTION.....	5
CHAPTER 4 - UNIQUE FEATURES .....	10
CHAPTER 5 - SENDER BAR LIMITS OF RESISTIVITY.....	11
CHAPTER 6 - INSTALLATION GUIDE.....	12
CHAPTER 7 - DISPLAY PROGRAMMING INSTRUCTIONS .....	19
CHAPTER 8 - TROUBLESHOOTING GUIDE.....	25
CHAPTER 9 - SPECIFICATIONS .....	27
CHAPTER 10 - SERVICE AND WARRANTY INFORMATION.....	28

Congratulations on purchasing the Garnet Instruments Model 806-B or 806-Bi SEELEVEL ANNIHILATOR™ Level Gauge for Tank Trucks. The ANNIHILATOR™ is a highly advanced device for liquid level measurement in transport applications. It is designed for reliable, accurate level measurement of non flammable liquids such as water, sewage, sludge, and many chemicals. The liquid level is determined by sensing the position of a magnetic float using a series of reed switches arranged in a vertical sensing bar. This technology has no moving parts except for the float, and can operate over a range of product temperatures from -40 °C to +90 °C (-40 °F to +194 °F).

The ANNIHILATOR™ has been designed to withstand the vibration and shock encountered in mobile applications. The 806-B has a weatherproof display enclosure for mounting outside of the cab of the truck, and the 806-Bi has a very compact sized display enclosure for mounting inside the truck cab. Both operate from 12 volt power, and use the same sender bar in the tank, which is weatherproof and able to withstand steaming temperatures.

The ANNIHILATOR™ can display in any units, such as inches of level, barrels, gallons, or cubic metres of volume. The display has four alarm outputs which can be used to warn of impending overfills or to shut down loading of the truck in an overfill or empty tank situation.

The 817-USB Truck Gauge Programmer is used to program the Annihilator to read the desired calibration units, and to set the alarm points. It is designed to be easily operated by people unfamiliar with electronics or computers.

The 806-B (Revision B) version of the Annihilator uses upgraded hardware and software to provide a number of enhancements over the earlier 806 and 806A series.

1. The display is multi-compartment, one display can accept up to three sender bars. The compartment number is displayed on the right hand LEDs and a push button is used to select the compartment. The number of compartments actually used in a given application can be programmed into the display so that only those compartments can be selected.
2. The display can be programmed directly with the 817-USB Truck Gauge Programmer, no adapter is needed.
3. One of the four alarms can function as an automatic self resetting alarm for high level warning. When the alarm is activated by a high level, it can be bypassed (silenced) by pressing the alarm button. When the tank is emptied, the alarm is re-activated for the next time the tank is filled. The status of the bypass is shown on the display.
4. The number of compartments, the current compartment number, the LED brightness (806-Bi) and the automatic alarm bypass reset status are retained even if power is removed, so the gauge will return to the same point of operation when power is restored.
5. A remote transmitter connection can be used to connect to a SeeLevel Access.
6. The 806-Bi in-cab version has adjustable LED brightness for comfortable viewing in all lighting conditions.
7. Firmware version 2.03 enables tank numbers from 4 to 9 to be displayed. This can be used in applications where there are more than 3 compartments being monitored by more than one display.
8. Firmware version 2.04 adds a rise alarm feature. This feature activates an alarm if the level in an unselected compartment rises more than one inch.

### How the Gauge Works

The Annihilator gauge consists of a sender bar, a donut shaped float, interconnect wiring, and a display. The sender bar is mounted vertically in the tank with the float sliding up and down around it in accordance with the fluid level. The sender bar sends the fluid level information via two wires to the display, which shows the level in appropriate units and operates the alarms. One display can monitor up to three compartments.

The float contains magnets which activate reed switches inside the stainless steel sender bar to indicate the level of the fluid. The activated switches are detected by the microprocessor at the top of the bar. A pair of wires (one signal and one ground) carry power from the display to operate the sender bar, and also carry the level information signal from the bar to the display. The power level on the signal wire is very low, so there is no danger of sparking or shock from this wire, and short circuits will not cause any damage. The signal from the bar is coded so that it is not affected by most electrical noise, moisture, or corrosion. If the signal is too badly degraded due to poor wiring, the system shuts down rather than showing an incorrect reading.

The display converts the level information to volume according to the calibration programmed into it with the 817-USB Truck Gauge Programmer. The calibration can be in inches or volumetric units such as cubic metres or barrels. The display also contains alarms that can be programmed to operate at specific tank levels and can be used to operate external devices. The in-cab display is enclosed in a compact plastic box which can be easily mounted anywhere in the truck cab, and the outside display is durable enough to withstand weather and indirect road spray. The tank level and compartment number is shown on a large LED (Light Emitting Diode) display which gives good all around visibility. The entire gauge operates from 12 volt truck power, consuming about 1/8 of an amp.

### Multi Compartment Operation

One display can have up to 3 sender bars connected (one bar per compartment), which is equivalent to 3 separate displays, except that you can only see one level and have one set of alarms at a time. This allows cost and space savings on the truck or trailer.

The compartment number is shown on the right side of the display, for example, C2 indicates compartment number 2. If the display has been programmed for only one compartment, then the compartment number is not shown.

Each compartment has its own volume and alarm calibration, so the compartments can be completely different in size and shape. When the compartment is changed, the volume display and alarms will change according to the calibration and tank level for the new compartment. If the self resetting alarm has been bypassed, that information is retained for each compartment, even if the compartment is changed or power is turned off.

To change which compartment the display is showing, press the **COMP** button on the right side of the display. Each time the button is pressed, the display will show the next compartment number. The display can also be configured to display compartment 1 with a trailing zero. In this case, only single compartment operation is possible. If the power to the system is turned off, the display retains the compartment number, so that when the power is turned on again, the same compartment will be shown.

Firmware versions 2.03 and 2.04 allow the display to show compartments 4 to 9. For example, if an application has 7 compartments, then three displays would be used. The first display would show compartments 1, 2, and 3. The second display would show 4, 5, and 6. The third display would show 7. This makes it much easier for the operator to keep track of which compartment is being monitored.

### **Multi Calibration Operation**

By connecting together 2 or 3 compartment wires on the display, it is possible to have different calibrations for the same tank, for example, gallons and barrels. In this case, instead of indicating compartments, the right display indicates which calibration is selected. Each calibration could have its own alarms as well.

### **Alarm Operation**

Each compartment has 4 alarms which can be set with the 817-USB programmer to turn on or off at any point in the tank. Alarms 1 and 2 are general purpose alarms which can be used for high or low level warnings or for controlling pumps or valves. If Alarm 4 is not used, then Alarm 3 can also be used as a general purpose alarm. These alarms can be programmed to be off below the set point and on above it, or they can be on below the set point and off above it. This allows the devices being controlled to turn on or off as the tank level rises or falls.

Alarm 4 is a dedicated high level warning alarm that turns on when the tank level rises past the set point. Normally a warning light or horn is connected to this alarm output. When the alarm is on, pressing the **ALARM BYPASS** button on the left side of the display will turn off (bypass) the warning. When the alarm is bypassed, the decimal points on the compartment indicator digits will light up. Pressing the alarm button when the alarm is off has no effect. Once the alarm has been turned off (bypassed), it will remain off until the tank level drops below the Alarm 3 set point, then rises

again above the Alarm 4 set point. Alarm 3 is normally set close to the bottom of the tank and is used to clear the bypass. This automatic system protects against the operator forgetting to turn the alarm back on for the next time the truck is loaded. The bypass indicator (compartment decimal points) serves to notify the operator that the alarm has been bypassed.

Each compartment has its own set of alarms and its own bypass memory. The bypass is retained for each compartment even if the compartment is changed or the gauge is turned off and on.

## Rise Alarm

This feature is first available in firmware version 2.04. The purpose of this alarm feature is to alert the user that the tank level is increasing in a compartment that is NOT selected for viewing. This helps to avoid spills due to a different compartment being viewed than is actually being filled, or due to a leaky or partially closed valve leading to a level increase in an unselected compartment. This feature operates when the display is set up for two or three compartments, it is not applicable for single compartment applications. If any compartment *not* selected has a level increase of more than one inch (2.5 cm) since the last time the compartment was selected, the display switches to that compartment, activates alarm 1 as a shutdown (typically to shut off the loading pump), and shows "r2" rather than "C2" on the compartment number display ("2" being an example of a compartment number). This alerts the user to the problem, and halts loading in applications where alarm 1 controls the loading pump. While the display has an active rise alarm, it is not possible to change the compartment, the display will immediately switch back to the compartment with the alarm. To resume operation, press the **ALARM BYPASS** button, this clears the rise alarm, clears alarm 1, and returns the "r" to a "C" on the compartment display. Turning the power off to the display and then back on will also clear a rise alarm. After a rise alarm is cleared, the rise alarm continues to monitor all unselected tanks for rise alarm events, it is not possible to "permanently" disable this feature.

If more than one compartment is experiencing a rise alarm, then the compartment display will cycle between the compartments that are experiencing the alarm. For example, if compartments 1 and 2 are in alarm, then the display will alternate between "r1" and "r2". Pressing the **ALARM BYPASS** button will clear the alarm on the compartment that is currently displayed, and then the display will switch to the remaining compartment in alarm. Pressing the button again, or continuing to hold the button down, will clear the alarm on this compartment. It is even possible to have all compartments in alarm if the initially selected compartment increases in level after the display switches to a different compartment. The rise alarm monitoring continues on the other compartments even when a compartment is in an active rise alarm state. If the level in an unselected compartment drops and then rises, the rise alarm will activate when the level rises more than one inch above the minimum level.

**WARNING: The use of alarm points is entirely at the owner's risk due to the nature of connecting external horns or lights, the reliability of external horns or lights, and the reliability of the power source and wiring required to operate them.**

### **Display Brightness (806-Bi only)**

The 806-Bi (in-cab model) has three brightness levels for the LED display to allow comfortable viewing in all lighting conditions. To increase the display brightness, press the **BRIGHT** button. Each time the button is pressed, the brightness is increased. When the maximum brightness has been reached, pressing the **BRIGHT** button has no effect. Similarly, to decrease display brightness, press the **DIM** button. The brightness level is retained in memory even if the gauge is turned off and on.

### **Installation Overview**

Installation of the gauge consists of cutting a hole in the top of each tank compartment and welding in a 1 inch coupler, and welding an anchor assembly to the bottom of the tank. The sender bar is cut to length, the end is sealed, and it is inserted from the top of the tank and fastened at the top with a compression fitting. The display is mounted at a convenient point on the truck or in the cab, and the wiring is run between the bar and the display. 12 volt power is brought into the display, any alarms are wired up, and the display is programmed with volume and alarm information. The bar can be removed later for service by disconnecting the wires, unscrewing the compression fitting, and pulling it out.

# GENERAL MECHANICAL ASSEMBLY

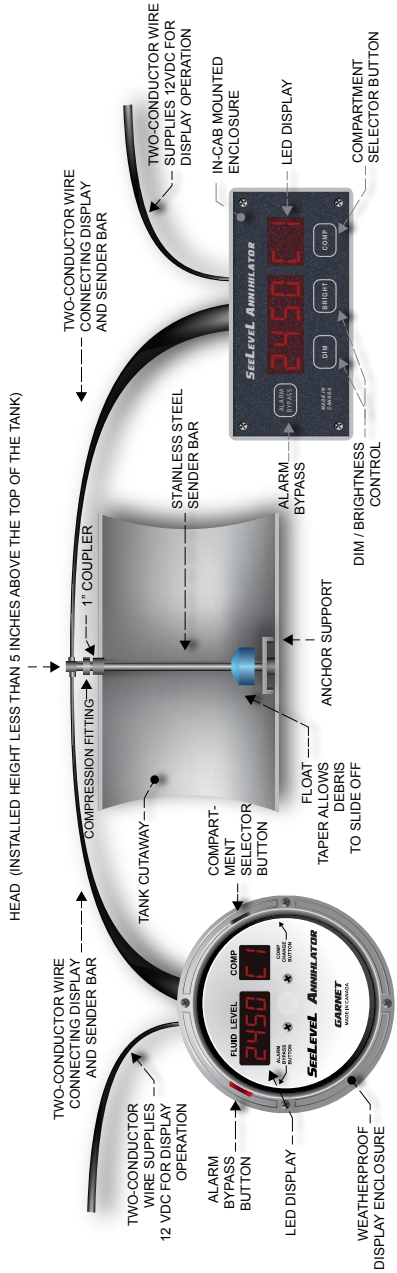

The Annihilator gauge has been designed for maximum ease of installation and servicing, and for best operational features. The anchor at the bottom of the tank provides a shock mount for the float, and holds the float in place if the sender bar is removed so no tank entry is required for bar replacement. If the new bar is cut to the same length as the old, no recalibration is required.

The float is molded from polyethylene for high chemical resistance, good esthetic appearance, and high durability due to the "give" in the plastic. The light weight of the polyethylene allows the float size to be minimized while allowing it to float on the lowest density products.

The sender bar has no moving parts and is completely filled with potting material to enhance reliability. The use of a digital rather than analog sensing technique ensures high accuracy with no drift or degradation. To accommodate different tank sizes, the bar is simply cut to length with a hacksaw, and the cut end sealed with a cap to prevent moisture or product contamination. This way only one size needs to be stocked, and a perfect fit is ensured. The sender bar top is very low in profile to satisfy rollover requirements; the maximum height is less than 4 inches above the top of the tank so that it will not protrude above the spillway.

The outside (806-B) display enclosure is waterproof, and the internal circuitry is also protected against moisture by a coating. The small size of all of the display enclosures also makes it easy to find an appropriate mounting location.

The use of an on-site programmer eliminates downtime waiting for factory calibration parts, and allows easy reprogramming should the need arise. The entire display, including decimal point, is completely programmable to whatever units are desired. In addition to numbers, the letters F, U, L, and E can be programmed to provide displays such as FULL, E, etc.

## CHAPTER 5 - SENDER BAR LIMITS OF RESISTIVITY

The temperature of the product being transported should be limited to approximately +90°C (+194°F). Damage to the float and sender bar can occur if this value is exceeded.

The tube used in the manufacturing of the sender bar is seamed 302/304 stainless steel. Seamless 316 stainless steel is optionally available. **It should be noted that certain corrosive products, as well as high concentrations of acid products, may attack the stainless steel and cause perforations to develop. It is the operator's responsibility to determine the products compatibility with the sender bar.**

**WARNING: Perforation of the sender bar or heat damage is not warrantable.**

The Loctite products used to secure the end cap can be attacked by certain chemicals as well. For reference, a chemical resistance chart from Loctite showing product compatibility with various chemicals can be found on the following pages.

The 680 retaining compound we specify is similar to Loctite #592, 567, 565, 569, 545, 580, 571, 242, 577, 572, 542, 565, 545, 243. If you require more information, please call the Loctite Corporation, in Canada, 1-800-263-5043, in USA, 1-800-562-8483.

1. Pick a spot in the tank for the sender bar(s) to be mounted. It should be as close to the middle of the tank compartment as possible. Make sure that the float will not contact any baffles or other obstructions in the tank. It is preferable if the float can be accessed from the hatch, to make any future service work easier. For this reason **do not** mount the float behind a baffle where it can't be reached from the hatch.
2. Drill or cut a hole in the top of the tank to mount a 1" NPT coupler (not provided). Weld the top coupler in place.
3. Slide the compression fitting over the sender bar, threads facing down, and insert the bar through the coupler and align it vertically in the tank. Determine how much material needs to be cut off the bottom of the bar. The bar should be mounted between 1" and 1.5" off the bottom of the tank to allow for tank expansion and contraction. Cut the bar with a hack saw and trim exposed circuit board with a sharp knife. **Do not use a disk type cutoff saw since the heat generated will short circuit the internal circuit board.**
4. **Ensure that the compression fitting is on the bar** and clean the end of the bar and the inside of the end cap with Loctite 7070 Cleaner. Spray Loctite T7471 Primer onto both the end of the bar and the inside of the end cap. Allow the primer to dry for a few minutes. Apply a bead of Loctite 680 Retaining Compound around the bottom of the tube and around the top of the end cap. Insert the cap onto the end of the tube with a turning motion. To remove entrapped air, place the end on the floor and rock the bar until excess air has escaped. Heat the end cap modestly with a butane torch or an electric heat gun until the end cap is quite hot to touch (but not over boiling). Keep the end cap in position by gently clamping the bar in a vise with the end against a solid object. Avoid setting the end cap against a cold floor, as this will slow the curing process. Reheat the end cap after 10 or 15 minutes with the cap restrained in position to allow curing to continue. The curing time should be about an hour. **The Loctite must be set before the tank is put into service. Bar failure due to a leaking end cap is NOT covered by warranty.** Note that a kit with all the required Loctite products is available from Garnet. For further details on the Loctite products see Technical Service Bulletin #17 on our web site.
5. Make up an anchor by cutting a 4" X 16" piece of 1/4" thick material. Bend each end down at 90 degrees (see the diagram below), so the resulting flat piece is about 4" X 10" inches with 3" sides. Drill a hole to insert a 2" ID schedule 40 pipe in the center of the plate, weld tube to plate. Insert the bar into the tank and slide the anchor assembly

over the sensor bar with the "U" facing down. Align the sensor bar vertically and weld the anchor in place to the bottom of the tank. Pull the sensor bar up a bit and slide the float (cone side up) over the bar. Lower the bar back into the anchor.

6. Tighten the base of the compression fitting into the coupler. Lift the bar 2 inches off the bottom of the tank, and tighten down the compression fitting nut. Raise and lower the float a few inches to set the bottom reading.

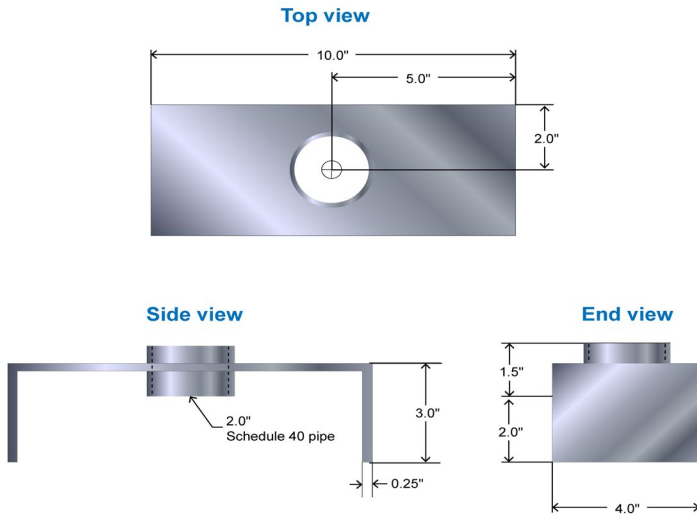

### FOR THE OUTSIDE (806-B) DISPLAY FOLLOW THESE STEPS:

1. Pick a spot for the display. It should be easy to see and out of direct road spray and protected from driving rain. Mount the display enclosure using the mounting flange holes, being certain to shim the enclosure away from the mounting surface with the spacers provided to allow water drainage. **Broken display enclosures caused by water freezing behind the enclosure are NOT covered by warranty.**
2. Route the sender bar wires together to the display, a cord is recommended, which will fit into a brass 1/4" NPT fitting or a good strain relief that is water tight, you will install it in the bottom half of the Betts housing. Water leaks are a threat to the system, be sure to vent the Betts housing by drilling another hole in the bottom using one of two methods:
  - a. If the readout is being housed in a box for weather protection, you may simply drill a 1/8 inch hole beside the brass fitting as near vertical as possible.

- b. If the readout is exposed to the elements, install another 1/4" NPT brass fitting with a 3-4 inch piece of 1/4" Synflex extending out of the fitting with a 45 degree slice at the termination point to prevent a sucking action in the airstream.
3. Inspect the head cap with the display circuitry for casting flash, and lightly sand or scrape off any casting protrusions. Make sure that there is grease on the rubber O-ring.

**FOR THE inside (806-Bi) DISPLAY FOLLOW THESE STEPS:**

1. Pick a spot for the display. Make sure that the display is visible from the driver's seat and from the door. Make up a bracket to hold the box in position and mount the box, but leave the front panel off. The front panel is held on by the four small Phillips screws in the corners. **DO NOT** remove the two larger Robertson screws.
2. Route the sender bar wires together in a protective jacket to the display in the truck cab, drill an entry hole for the wires to enter the back of the box and connect as listed below in the chart.
3. When you are ready to fasten on the front panel with the four Phillips screws in the corners, remember that the screws are small so **do not** over tighten them. The screws are in soft plastic so they do not need to be really tight to keep from backing out.

 **CAUTION:** All enclosures with an o-ring must be cleaned and greased periodically. WATER DAMAGE IS NOT WARRANTABLE.

## FOR BOTH DISPLAY TYPES FOLLOW THESE STEPS:

At the display, use the terminal blocks to connect the wiring according to this table.

TERMINAL	CONNECTION
GND	Truck ground and <b>BLACK</b> bar wire(s)
+12V	12 volt ignition power source (fused: see below) *
COMP 1	<b>YELLOW</b> wire from comp #1 bar
COMP 2	<b>YELLOW</b> wire - comp #2 bar (if used)
COMP 3	<b>YELLOW</b> wire - comp #3 bar (if used)
ALARM 1	External device controlled by alarm 1
ALARM 2	External device controlled by alarm 2
ALARM 3	External device or reset point for Alarm 4 **
ALARM 4	Warning light or horn **
REMOTE	For connecting to 828
COMP BUT	Compartment button switch
ALRM BUT	Alarm bypass button switch

**\*NOTE:** Connect +12 Vdc power source via a minimum 1-amp fuse.

**\*\*NOTE:** Alarm 3 can behave the same way as Alarm 1 and 2, or Alarm 3 can be used as the reset point for Alarm 4.

### ***For firmware versions 2.03 and 2.04***

TERMINAL	CONNECTION
COMP 1	<b>YELLOW</b> wire from comp #1, #4, or #7 bar
COMP 2	<b>YELLOW</b> wire from #2, #5, or #8 bar (if used)
COMP 3	<b>YELLOW</b> wire from comp #3, #6, or #9 bar (if used)

1. You may want to put a switch in the power line to shut off the display if the light from the LED's would be annoying at night. It is recommended that this switch be located in the dashboard.
2. Note that the alarms provide a circuit connection to ground when they turn on. If the alarm load is more than 1-amp, a relay should be used to prevent damage to the alarm outputs.

3. The other terminals on the Compartment button switch and the Alarm button switch should be connected to ground.
4. If the display is powered up before the sender bar is connected, it will read "**no S**" indicating that it is not receiving a signal from the sender bar. If the wiring to the bar is shorted to ground, the display will read "**Shrt**".
5. Program the gauge as directed in the programming section. To determine the bottom reading of the gauge, measure from the bottom of the tank to the seam in the middle of the straight vertical part of the float. Make sure the float is resting on the anchor when this measurement is done. Do **NOT** set the gauge to read "0" at the bottom since this will not result in a correct reading when the float is actually floating on the product. In addition, if the gauge ever goes below "0" due to tank expansion, it will read some nonsensical value since this region has not been programmed.
6. From the inside, seal all wire entries into the display enclosure with RTV silicon rubber. Make sure that the RTV fully surrounds the wire where it goes through the fitting.
7. Close up the display by attaching the front panel. The 806-B will snap on while the 806-Bi cover needs to be screwed on.
8. Verify gauge operation by lifting the float.

# 806-B WIRING DIAGRAM-THREE COMPARTMENT WITH ALARM INDICATORS, ALARM HORN, AND REMOTE SERIAL INTERFACE CONNECTION

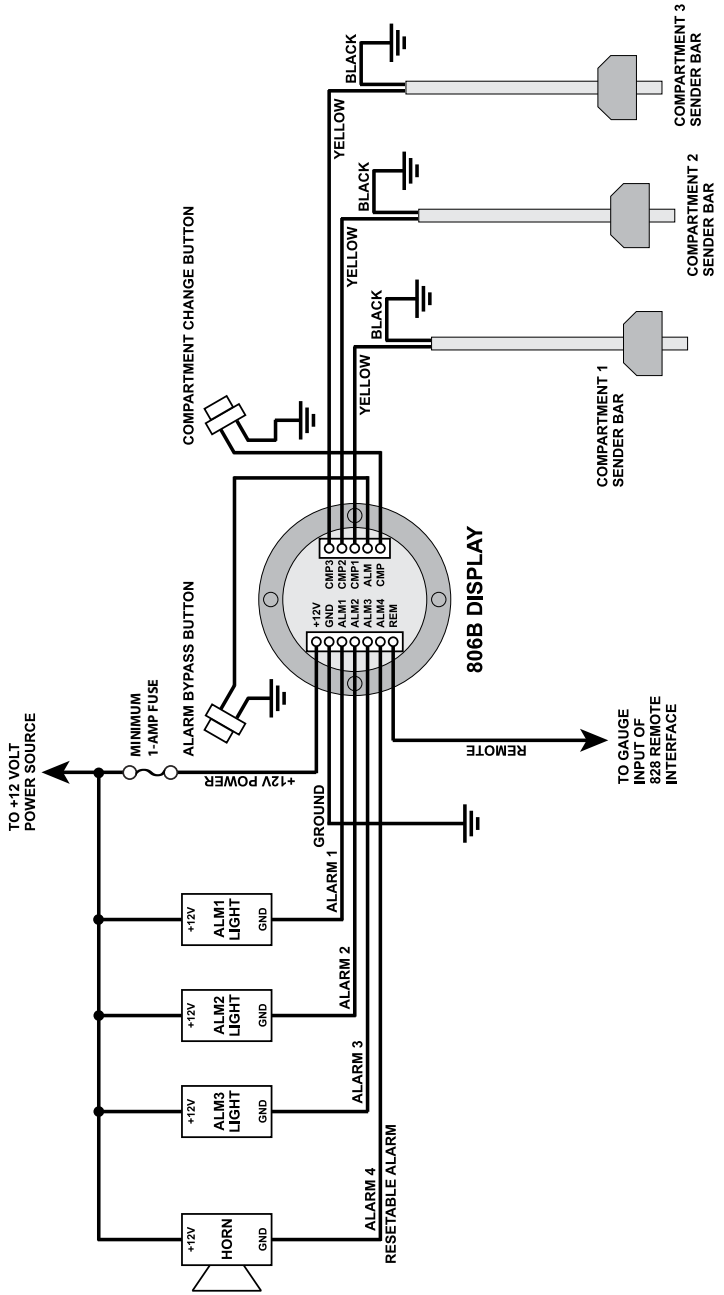

# 806-B MULTI COMPARTMENT, MULTI DISPLAY WIRING EXAMPLE

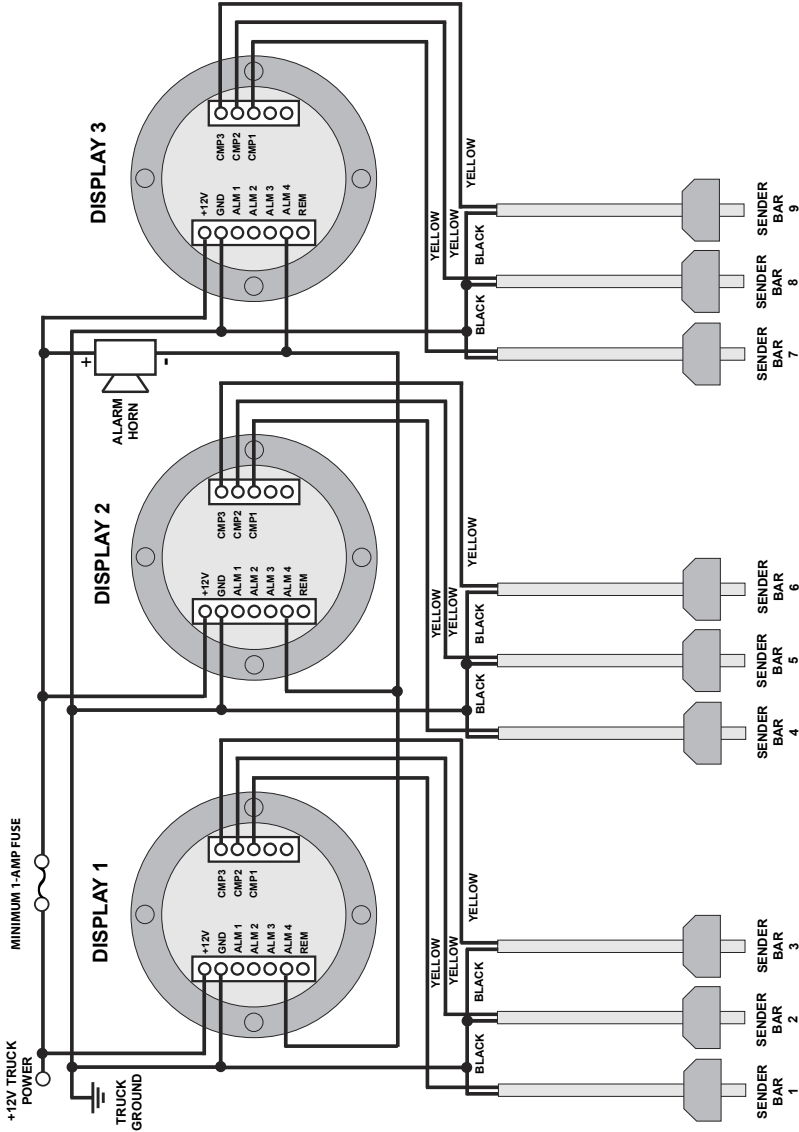

**THIS EXAMPLE SHOWS 9 COMPARTMENTS CONNECTED TO 3 OUTSIDE DISPLAYS.  
IT ALSO SHOWS ALARM 4 FROM ALL DISPLAYS CONNECTED TO A COMMON ALARM HORN.**

The 806 Annihilator provides a very interactive programming experience. When the programming plug is connected to the gauge, the gauge display will show "**prog**" within a second. Do not start programming the gauge until "**prog**" is shown. When the programming plug is removed, the display will show "**donE**" for a couple of seconds.

### Notes:

1. 12VDC power must be applied to the gauge display in order to program it.
2. The bar must be connected and operating in order to set the bottom reading on the gauge.
3. Each compartment must be programmed separately. To program a given compartment, use the **COMPARTMENT** button on the back of the 806-B display to select the compartment to be programmed, as shown on the right hand side of the display. Use the **COMP** button on the front of the 806-Bi display. The programmer must be unplugged from the display when changing compartments.
4. To make the 806-B display read in inches, press the **INCH** button on the back of the display. To make the 806-Bi display read in inches, press the **DIM** and **BRIGHT** buttons at the same time.
5. There are three compartment terminal blocks but four possible compartment modes. The **COMP** button switches through the four modes, C-1, C-2, C-3 and C-1 **with a trailing zero**.
6. Firmware versions 2.03 and 2.04 have 10 possible compartment modes, C-1 through C-9, and C-1 with a trailing zero.

### ***Program the Annihilator for the number of compartments:***

1. The display is capable of working with one, two, or three sender bars. It must be programmed for the number of sender bars used, otherwise it will attempt to show unused compartments, or will not show used compartments.
2. Firmware versions 2.03 and 2.04 must be programmed to reflect both the number of sender bars and the number of displays in the application.
3. The 817-USB programmer is not needed for this programming. No programming is possible or required for the sender bars.
4. Connect 12 volt power to the display, but do not connect any sender bars. The display should show "**no S**".

5. Press and hold the **INCH** button (806-B) or the **DIM** and **BRIGHT** buttons (806-Bi). After about 5 seconds, the display will enter the "program number of compartments" mode by showing "**P no. C1**", "**P no. C2**", "**P no. C3**", or "**PTro C1**" **depending on** what is currently programmed (1, 2, 3 compartments, or 1 with trailing zero). Release the button(s) at this point. Firmware versions 2.03 and 2.04 will show from "**Pno C1**" to "**Pno C9**", or "**PTro C1**"
6. Press the **COMPARTMENT** button to change the right hand number to the correct number of compartments. Do this within 5 seconds or the display will exit the programming mode. For firmware versions 2.03 and 2.04, see the following table to select the correct number of compartments for a display.
7. When the display shows the correct number of compartments, do not press any button for 5 seconds. The display will then show "**Stor C1**", "**Stor C2**", "**Stor C3**", or "**Stor 0**" indicating that 1, 2, 3 compartments or the trailing zero has been stored. The display will then return to normal operating mode. For firmware versions 2.03 and 2.04, the display will show "**Stor C1**" to "**Stor C9**" or "**Stor 0**".
8. Test the display by repeatedly pressing the **COMPARTMENT** button. The compartment number should go 1-2-3-1-2-3 etc. for a three compartment system, 1-2-1-2 etc for a two compartment system. If only one compartment is used, then the compartment number is not shown or a "0" is shown for the trailing zero mode and the **COMPARTMENT** button has no effect.
9. For firmware versions 2.03 and 2.04, the compartment number will go 1-2-3-1-2-3 for display 1, 4-5-6-4-5-6 for display 2, or 7-8-9-7-8-9 for display 3. If only one compartment is used and the trailing zero mode is not selected, then the compartment number is not shown on display 1. However, if display 2 is programmed for one compartment, it will show "**C4**", similarly, if display 3 is programmed for one compartment, it will show "**C7**".
10. The number of compartments can be reprogrammed at any time if required. The display must show "**no S**" on the selected compartment to be able to enter the programming mode.

## 806 Multi Compartment Display Programming and Wiring Guide

Number of compartments	Display 1 programming	Display 1 wiring	Display 2 programming	Display 2 wiring	Display 3 programming	Display 3 wiring
1 with trailing zero	Ptr0 C1	Sender bar 1 to COMP 1	Not Applicable	Not Applicable	Not Applicable	Not Applicable
1	P no.C1	Sender bar 1 to COMP 1	Not Applicable	Not Applicable	Not Applicable	Not Applicable
2	P no.C2	Sender bar 1 to COMP 1 Sender bar 2 to COMP 2	Not Applicable	Not Applicable	Not Applicable	Not Applicable
3	P no.C3	Sender bar 1 to COMP 1 Sender bar 2 to COMP 2 Sender bar 3 to COMP 3	Not Applicable	Not Applicable	Not Applicable	Not Applicable
4	P no.C1	Sender bar 1 to COMP 1	P no.C4	Sender bar 4 to COMP 1	Not Applicable	Not Applicable
5	P no.C2	Sender bar 1 to COMP 1 Sender bar 2 to COMP 2	P no.C5	Sender bar 4 to COMP 1 Sender bar 5 to COMP 2	Not Applicable	Not Applicable
6	P no.C3	Sender bar 1 to COMP 1 Sender bar 2 to COMP 2 Sender bar 3 to COMP 3	P no.C6	Sender bar 4 to COMP 1 Sender bar 5 to COMP 2 Sender bar 6 to COMP 3	Not Applicable	Not Applicable
7	P no.C1	Sender bar 1 to COMP 1	P no.C4	Sender bar 4 to COMP 1	P no.C7	Sender bar 7 to COMP 1
8	P no.C2	Sender bar 1 to COMP 1 Sender bar 2 to COMP 2	P no.C5	Sender bar 4 to COMP 1 Sender bar 5 to COMP 2	P no.C8	Sender bar 7 to COMP 1 Sender bar 8 to COMP 2
9	P no.C3	Sender bar 1 to COMP 1 Sender bar 2 to COMP 2 Sender bar 3 to COMP 3	P no.C6	Sender bar 4 to COMP 1 Sender bar 5 to COMP 2 Sender bar 6 to COMP 3	P no.C9	Sender bar 7 to COMP 1 Sender bar 8 to COMP 2 Sender bar 9 to COMP 3

## ***Program the Annihilator gauge display into inches:***

1. Turn on the programmer.
2. Make sure the inch mode is correct.
3. Select a memory location with **MEM LOC**.
4. Press the **INCH MEM (SHIFT – 1)** button to put inches into the memory. If the inches are already in memory from a previous calibration, it is not necessary to do it again, but make sure that they are the correct inches (1/4”).
5. To program the alarm points, determine the level that they should be set at and whether they should be start up or shut down. The start up mode turns the alarm on as the tank level rises past the alarm point (i.e., the alarm is on at the top of the tank, and off at the bottom). The shut down mode turns the alarm off as the tank level rises past the alarm point (i.e., the alarm is on at the bottom of the tank, and off at the top).
6. If the automatic alarm is to be used, program Alarm 4 as shut down at the point where the horn is to come on, and program Alarm 3 as shut down a few inches above where the float will sit at the bottom of the tank. The automatic alarm is a special output so that even though Alarm 4 is programmed as shut down, the horn will be turned on when the level rises above the Alarm 4 point, and then will turn off when the alarm is silenced. When the fluid level goes below the Alarm 3 point, the alarm will be re-armed so it will sound the next time the level goes above Alarm 4.
7. To set Alarm 1, use the **INCHES** buttons to obtain the desired set point on the CALIBRATION display, then press the **ALARM SHUT DN** or **SHIFT-ALARM ST UP** button followed by the **1** button. When the operation is complete, repeat this procedure for the other alarms, pressing **2, 3**, and then **4** after the **ALARM** button. If an alarm is not used it does not need to be programmed.
8. Make sure that the wires from the sender bar are connected to the gauge display, and plug the programmer plug into the gauge display. Press the **BAR** button. The INCHES display should show some inch reading, if it shows “**no S**” or “**No FL**” check the wiring.
9. Measure the distance from the bottom of the tank to the middle of the float, this is the bottom reading. Use the **OFFSET** buttons to obtain this reading on the CALIBRATION display. **NOTE:** The calibration offset is carried over when memory locations are changed.
10. Press the **PROG** button to transfer the calibration to the gauge.
11. When the operation is complete, unplug the programmer from the gauge and verify gauge operation.

### ***Copy one Annihilator gauge display to another:***

1. Turn on the programmer.
2. Make sure the inch mode is correct (1/4").
3. Select a memory location with **MEM LOC**.
4. Plug the programmer plug into the gauge display to be copied from. Press the **COPY** button to copy the gauge calibration into memory.
5. When the operation is complete, unplug the programmer plug from the first gauge and plug it into the gauge display to be copied to. Press the **PROG** button to transfer the calibration to the second gauge.
6. When the operation is complete, unplug the programmer from the gauge and verify gauge operation.

### ***Program an Annihilator gauge display from a table of calibration values:***

1. Obtain a table of inches versus volume
2. Turn on the programmer.
3. Make sure the inch mode is correct (1/4").
4. Select a memory location with **MEM LOC**.
5. Press the **CLEAR MEM** button to erase any previous calibration.
6. Starting at the 0 inch value of volume calibration, use the **0** to **9**, decimal, **E**, **F**, **L**, **U**, or **BL** buttons on the keypad to enter the calibration. Press the **ENTER** button to store the value in memory. When **ENTER** is pressed, the inches will go to the next value. If you make a mistake, use the **BACK** button to erase the entry, or if **ENTER** has already been pressed, use **INCHES ↓** to go back to that inch value and re-enter the correct value. If more than 4 numbers are entered the previous ones will scroll off the left of the display. If **ENTER** is pressed before any numbers, nothing will happen.
7. After the table has been entered, use the **INCHES** buttons to review the table to make sure it is correct. If a calibration value is incorrect, simply re-enter it and press **ENTER**.
8. Continue with the same procedure as in Program the gauge display into inches from step 5. When setting the bottom reading, use the calibration table to look up the volume corresponding to the distance to the middle of the float. Use the **OFFSET** buttons to obtain this reading on the CALIBRATION display.

***Program an Annihilator gauge display from a table stored in memory:***

1. Turn on the programmer.
2. Make sure the inch mode is correct (1/4").
3. Select the desired memory location with **MEM LOC**.
4. Continue with the same procedure as in **Program the gauge display into inches** from step 5. When setting the bottom reading, use the calibration table to look up the volume corresponding to the distance to the middle of the float. Use the **OFFSET** buttons to obtain this reading on the CALIBRATION display.

***Programming the alarms to use the automatic self resetting alarm for high level warning:***

1. To use this alarm, the warning device (light or horn) must be connected to Alarm 4.
2. Turn on the programmer. Make sure you have the correct volume calibration showing in the Calibration Display.
3. For this application, alarm 4 is the warning point and alarm 3 is the tank empty point. Alarm 4 must be higher than alarm 3. Both of the alarms are programmed as shutdown. Note that even though Alarm 4 is programmed as shut down, the alarm will turn on as the tank level rises past the alarm set point.
4. Select the point in the tank where the warning should turn on. Use the **INCHES** buttons to obtain the desired set point on the CALIBRATION display.
5. Then press the **ALARM SHUT DN** button followed by the 4 button. This programs alarm 4 as a shutdown with the warning value.
6. Select a point in the tank which is a few inches off the bottom. The product level must go below this point when unloading, but once the tank has been even partially filled the product level should be above this point. Use the **INCHES** buttons to obtain this point on the Calibration Display.
7. Then press the **ALARM SHUT DN** button followed by the 3 button. This programs alarm 3 as a shutdown with the tank empty value. When the product level drops below this point the warning bypass is reset.
8. This completes the alarm programming. Alarms 1 and 2 are not used for the automatic self resetting alarm for high level warning. Program the gauge according to the appropriate instructions above.

There are only 4 serviceable components in the gauge: the float, the sender bar, the interconnecting wire, and the display.

If the float is sunk, the display will read the bottom tank reading all the time. If the float is partially sunk, the reading may rise and then fall as the tank is filled. If the float is lost from the bar, or if the float magnets are all damaged or lost, the bar will output a 0.0 inch signal which will be displayed as "**FLoT**" indicating that the float is missing or not working.

If the wires are cut or the sender bar is dead, the display will read "**no S**" indicating that it is not receiving a signal from the sender bar. If the wiring to the sender bar is shorted to ground, it will show "**Shrt**". In rare cases a shorted sender bar could cause a short circuit reading, disconnecting the yellow wire at the sender bar will change the display reading to "**no S**" in this case.

If the display reads erratically, check for water inside the display, and for a poor end cap seal. If the display is receiving a corrupted or inadequate signal it will show "**Err**" indicating an error in the bar signal.

If the display reads "**EPro**" this indicates an internal memory failure and requires the display to be replaced

If the display shows "**Prob**" at all times, it indicates an internal memory corruption of the number of compartments. Try reprogramming the number of compartments, if this fixes the problem then no further action is needed. If not, then the display will need to be serviced.

### To test a sender bar:

1. Connect the bar to a display that is known to be operational. Program the display to inches, or hold down the inch button on the back of the display.
2. By running a float up and down the bar you should see the inch numbers on the display rise and fall. If it shows "**no S**" or "**Err**" or "**Shrt**" the bar needs to be replaced.

## To test a display:

1. Connect the display to a bar that is known to be good. Run the float up and down on the bar to see if the display responds properly.
2. If the display shows some strange reading it may need reprogramming. Copy the existing programming into an unused memory on the 817-USB (just in case) and then program the display in inches or a known good program. The display should show "prog" within a second of plugging in the 817 plug, if not it is bad. After the 817 plug is removed the display readings should match the readings on the 817 calibration display, if they do not then the display is bad.
3. If only the alarms do not work then copy the calibration into the 817-USB to check if the alarms are programmed. If they are programmed then connect the sender bar to the display. Connect the positive lead of an ohm meter to the alarm terminal, and the negative lead of the ohm meter to the ground terminal. Run the float up and down on the bar to test the alarms.

The firmware version can be displayed on an 806-B by pressing both the **INCH** button and **COMPARTMENT** button for 5 seconds when "**No S**" is shown. The firmware version can also be displayed on an 806-Bi by pressing the **DIM** button, **BRIGHT** button and **COMPARTMENT** button for 5 seconds when "**No S**" is displayed. The firmware code version number will be displayed until the buttons are released, for example "**Cod2.03**" or "**Cod 2.04**".

## CHAPTER 9 - SPECIFICATIONS

806-T SENDER BAR	
Resolution	6 mm (1/4")
Accuracy	+/- 0.5 cm (+/-0.2")
Bar construction	304 stainless steel tube, 25 mm (1") dia 316 seamless stainless steel (optional upgrade) Fitting: 25 mm (1") NPT male compression fitting Update (sample) rate: 56 mS (milliseconds)
Enclosure material	PBT plastic, Lid: polycarbonate
Maximum tank height	Tank height up to 221 cm (87")
Product temperature range	-40°C to +90°C (-40°F to +194°F)
Power	Powered by 12 Vdc truck power through the display
Alarm output range	1 amp at 15 Vdc
Input power	10-15 Vdc, 180 mA max. (minimum 1-amp fuse)
Float material	Medium density polyethylene. Stainless steel float available (optional upgrade).
Float size	Cylindrical, 178 mm (7") in diameter, 114 mm (4½") high.
Float buoyancy	Sinks 25 mm (1") in water.
806-B DISPLAY	
Material	Enclosure: PBT plastic, Lid: polycarbonate
Size	Enclosure size: 152 mm (6") in dia x 70 mm (2¾") deep
Display type	0.56" red LED, 4 volume digit, 2 compartment digits
External power	Powered by 12 Vdc truck power
Ambient temperature range	-40°C to +60°C (-40°F to +140°F) ambient
806-Bi DISPLAY	
Material	Enclosure: ABS plastic
Size	127 mm wide x 64 mm high (5"x 2½") x 43 mm (1 2/3") deep
Display type	0.56" red LED, 4 volume digit, 2 compartment digits
External power	Powered by 12 Vdc truck power
Ambient temperature range	-40°C to +60°C (-40°F to +140°F) ambient
SAFETY INFORMATION	
Compliance and Certifications	<p>CAN ICES-001(A)/NMB-001(A)</p> <p>This device complies with part 15 of the FCC Rules. Operation is subject to the following two conditions: (1) This device may not cause harmful interference, and (2) this device must accept any interference received, including interference that may cause undesired operation.</p> <p>Changes or modifications not expressly approved by the party responsible for compliance could void the user's authority to operate the equipment.</p> <p>This product can expose you to chemicals including Nickel and Lead, which are known to the State of California to cause cancer, and lead which is known to the State of California to cause birth defects or other reproductive harm. For more information go to <a href="http://www.P65Warnings.ca.gov">www.P65Warnings.ca.gov</a></p> <p>Changes or modifications not expressly approved by the party responsible for compliance could void the user's authority to operate the equipment.</p>

Find warranty claim process information refer to our support page on our website:

[www.garnetinstruments.com/support/](http://www.garnetinstruments.com/support/)

### DISCLAIMER OF WARRANTY ON HARDWARE

Garnet Instruments warrants equipment manufactured by Garnet to be free from defects in material and workmanship under normal use and service for a period of three years from the date of sale from Garnet or an Authorized Dealer. The warranty period will start from the date of purchase or installation. Under these warranties, Garnet shall be responsible only for actual loss or damage suffered and then only to the extent of Garnet's invoiced price of the product. Garnet shall not be liable in any case for labor charges for indirect, special, or consequential damages. Garnet shall not be liable in any case for the removal and/or reinstallation of defective Garnet equipment. These warranties shall not apply to any defects or other damages to any Garnet equipment that has been altered or tampered with by anyone other than Garnet factory representatives. In all cases, Garnet will warrant only Garnet products which are being used for applications acceptable to Garnet and within the technical specifications of the particular product. In addition, Garnet will warrant only those products which have been installed and maintained according to Garnet factory specifications.

### LIMITATION ON WARRANTIES

These warranties are the only warranties, expressed or implied, upon which products are sold by Garnet and Garnet makes no warranty of merchantability or fitness for any particular purpose in respect to the products sold. Garnet products or parts thereof assumed to be defective by the purchaser within the stipulated warranty period should be returned to the seller, local distributor, or directly to Garnet for evaluation and service. Whenever direct factory evaluation, service or replacement is necessary, the customer must first, by either letter or phone, obtain a Returned Material Authorization (RMA) from Garnet Instruments directly. No material may be returned to Garnet without an RMA number assigned to it or without proper factory authorization. Any returns must be returned freight prepaid to: Garnet Instruments, 286 Kaska Road, Sherwood Park, Alberta, T8A 4G7. Returned warranted items will be repaired or replaced at the discretion of Garnet Instruments. Any Garnet items under the Garnet Warranty Policy that are deemed irreparable by Garnet Instruments will be replaced at no charge or a credit will be issued for that item subject to the customer's request.

If you do have a warranty claim or if the equipment needs to be serviced, contact the installation dealer. If you do need to contact Garnet, we can be reached as follows:

#### CANADA

Garnet Instruments  
286 Kaska Road  
Sherwood Park, AB T8A 4G7  
CANADA  
email: [info@garnetinstruments.com](mailto:info@garnetinstruments.com)

#### UNITED STATES

Garnet US Inc.  
5360 Old Granbury Road  
Granbury, TX 76049  
USA  
email: [infous@garnetinstruments.com](mailto:infous@garnetinstruments.com)