

SEELEVEL Soul™

MODULE



INSTALLATION MANUAL

MODEL 708-RBT

with *Bluetooth*®

SENDERS
710-AR2 | 710-ES3 | 710-SS2

Printed in Canada

CANADA
Garnet Instruments Ltd.
286 Kaska Road
Sherwood Park, AB T8A 4G7

USA
Garnet US Inc.
5360 Old Granbury Road
Granbury, TX 76049

GARNET
Liquid management solutions, your way.

RVgauge.com | 1-800-617-7384

INTRODUCTION

The SeeLevel Soul™ 708-RBT is a data link module designed for RV OEMs as a cost-effective solution. It is designed to be mounted in a concealed part of the RV by the OEM and connects to multiplex systems via the RV-C bus. It can monitor up to seven holding tanks; two FRESH, three GREY, and two BLACK tanks.

The SeeLevel Soul™ collects tank level information from the SeeLevel senders and transmits it to a multiplex system. The information is also viewable through *Bluetooth*® on the SeeLevel RV monitoring app. The 708-RBT Soul configuration app is available on all major app store platforms, and allows the user to setup the 708-RBT Soul to match the tank configuration of the RV. It is also a diagnostic tool to aid in troubleshooting.

TABLE OF CONTENTS

Select from contents list below to go to that page.

INTRODUCTION	1
SAFETY INFORMATION	2
INSTALLATION INFORMATION	2
Installation Documentation Downloads	2
Model and Serial Number Information	2
ABOUT THE SYSTEM	3
CONNECTORS	4
COMMUNICATIONS	4
SENDER INSTALLATION	5
WIRING DIAGRAM	11
MODULE INSTALLATION	14
TROUBLESHOOTING GUIDE	15
RV-C Diagnostics	15
Single Diagnostic LED patterns	15
Wiring Diagnostics Flowcharts	16
Troubleshooting & Installation Tips	17
WARRANTY & SERVICE INFORMATION	19
SPECIFICATIONS	19
APPENDIX A	20
Bluetooth Information	20
APPENDIX B	20
RV-C Data FAQ	20

708-RBT Manual_v2.3 - 31-Mar-2026

SAFETY INFORMATION

Read these instructions carefully and look at the equipment to become familiar with the device before trying to install, operate, service, or maintain it. The following special messages may appear throughout this manual or on the equipment to warn of potential hazards or to call attention to information that clarifies or simplifies a procedure. "Notes", "Cautions", and "Warnings" have been used to bring special matters to the immediate attention of the reader.

Safety Symbols

⚠ WARNING: explains dangers that might result in personal injury or death.

ℹ NOTE: expands on information for any procedures.

⚠ CAUTION: explains safety information that could cause damage to the product, including data loss.

Changes or modifications not expressly approved by the party responsible for compliance could void the user's authority to operate the equipment.

2026 Garnet Instruments. All rights reserved. No part of this publication may be reproduced, Transmitted, transcribed, stored in a retrieval system or translated into any language in any form by any means without the prior written consent of Garnet Instruments. Information in this manual is subject to change without notice and does not represent a commitment on the part of GARNET.

INSTALLATION INFORMATION

Installing the complete system involves cutting and mounting the senders to the tank sides, securing the module in a concealed location within the RV, connecting the wiring, programming the module, and configuring the display.

Installation Documentation Downloads

All documentation that is required to complete installation and user guides can be downloaded from the website Resource Library either by selecting the link below or scan the QR code and search for your model.

www.garnetinstruments.com/holding-tanks-resource-library/

- Installation Guide
- Configuration Tool App (iOS & Android)
- SeeLevel RV 2.0 Bluetooth App manual



Model and Serial Number Information

Before installing your system, look for the model and serial number on the side of the module, as shown below. Document these numbers for future reference.

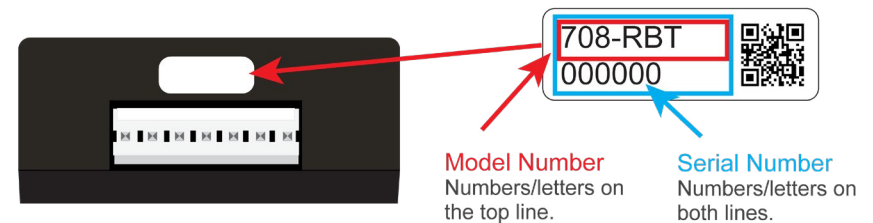

ABOUT THE SYSTEM



The 708-RBT Soul Module

The SeeLevelL Soul receives the information from the senders through a two conductor bus, and reports the level information on the RV-C bus and through Bluetooth at the same time. The system is design to provide highly accurate fluid level readings.

The Senders

Senders are flexible and meant to self adhere to the outside of the holding tank. The sender can be cut to length to match the height of the tank, and will automatically calibrate to its cut length, providing a full to empty reading for any tank height.

In addition to the level, the sender also transmits diagnostic information about its operation. This information can be used to determine if there is buildup on the inside of the tank, or to determine if the sender is damaged or delaminating from the side of the tank. If sludge buildup in the tank becomes extreme, the gauge will stop functioning properly. By monitoring the signal strength, the tank can be cleaned before the buildup reaches an excessive level.

The different sender options are available; 710-AR2, 710-ES3, and 710-SS2, and the ability to double stack the senders provides accurate level measurement for tank heights ranging from 3.5" to 34". **See "Sender Configuration" section for available sender options.**

NOTE: New sender models 710-AR2 and 710-ES3 can be combined with older sender models 710-ES2, 710-JS, 710-SS but can only do up to 4 tanks (Fresh, Grey, Galley, Black tanks).

Diagnostics

When the sender is working correctly and properly connected to the 708-RBT Soul, the level will display as expected. If there's a problem, like disconnected wiring or a faulty sender panel, the 708-RBT Soul will show an error code instead. Details about these error codes are in the "TROUBLESHOOTING GUIDE" section.

In the unlikely event of an incorrect liquid level indication, the diagnostic features of the 708-RBT Soul module greatly aids in servicing.

Battery Voltage

The 708-RBT Soul also provides the RV battery voltage by measuring the voltage which powers the module. The voltage is shown with a resolution of 0.1 volt.

LPG

The 708-RBT Soul module can measure the level of one LPG tank by connecting to the resistive based measuring points that are built into some LPG tanks. The 708-RBT Soul comes from the factory set to assume that 0Ω is empty and 100Ω is full, but can be re-calibrated to other resistance ranges.

RV-C

The 708-RBT Soul transmits tank level information onto a CAN bus using the RV-C protocol, allowing it to integrate with most RV multiplex systems.

CONNECTORS

It is easier to connect the wiring to the module pigtail first, and then plug the connector into the module panel. The device has two basic connectors: 7-Pin pigtail harness and a RV-C CAN connector.

7-Pin Pigtail Harness: provides Power, Ground, Sender, LPG, and CAN Bus connections. A pigtail cable assembly with 12" AWG18 wires is included.



Wire Colours on 7-Pin Connector



	Wire Color	Function
1	Red 18 gauge	+12Vdc Main Power
2	Blue 18 gauge	Senders
3	Green 18 gauge	LPG
4	Purple 18 gauge	CAN-Hi
5	Yellow 18 gauge	CAN-Lo
6	Black 18 gauge	Ground
7	-	-

Micro USB port  **RV-C 4-Pin Connector**



Micro USB port: Used to connect the module to a computer for configuration purposes. A standard Micro-USB cable can be used.

RV-C CAN Connector: RV-C is a communications protocol based on CAN BUS that is used for control, coordination, and diagnostics. It provides an alternate connection point for the 708-RBT Soul's CAN bus connection.

COMMUNICATIONS

RV-C connectivity: The sensors use a default source address of 72 and SPN-ISB instances are 0 for fresh, 1 for black, 2 for grey. If more than one tank of any instance is configured in the system, then the SPN-ISB instance for the second item will be reported with a shift of 16 from the previous. For example: the first fresh tank SPN-ISB instance will be 0 but for the second fresh tank it will be 16 and for the third tank 32 and so on. The same procedure applies to the sewer types grey and black. The LPG sensor use the default source address of 73 and SPN-ISB instances 3 and 19.

1. By disabling the LPG or changing the FRESH/GREY/BLACK to zero senders, you will also disable that sender's updates over the RV-C bus.
2. The RV-C has a 4-pin connector as shown below.

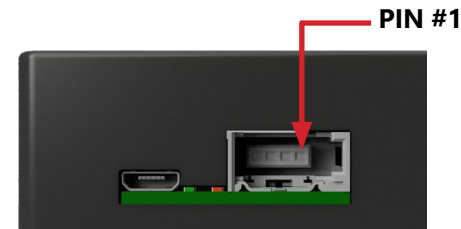

RV-C CAN Connector

Pin Number	Signal Description
1	No connection
2	CAN-Hi
3	CAN-Lo
4	GND

Bluetooth connectivity:

The 708-RBT Soul has Bluetooth® wireless technology, which allows you to check your tank levels, battery voltage, and LPG tank levels on any compatible smartphone or tablet using the SeeLevel RV 2.0 app. The app is free downloadable app available on Google Play and iOS app stores.

(See separate manual for app installation and operation.)

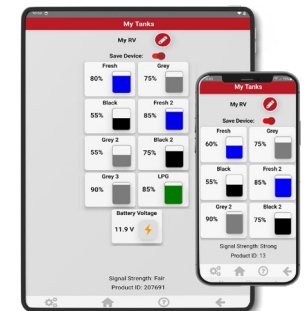

SENDER INSTALLATION

Garnet offers three different sender options. They work on most plastic or polyethylene holding tanks that contain water-soluble fluids and are not compatible with metal holding tanks.

The 710-AR2 is 9" high. The higher resolution is 0.25" which is optimal for low-profile tanks. This sender is ideal for tanks 3.5"-11" tall but can be stacked with an additional 710-AR2 to measure tanks as tall as 20".

The 710-ES3 sender is 12" high. It has a resolution of 0.33" and is the most popular option, designed to measure liquid levels in most standard holding tanks. It is ideal for tanks 4.5"-14" tall but can be stacked with an additional 710-ES3 to measure tanks as tall as 26".

The 710-SS2 sender is 16" high. It has a resolution of 0.44" designed for taller tanks. It is ideal for tanks 7.5"-18" tall but can be stacked with an additional 710-SS2 to measure tanks as tall as 34".

See more information about sender lengths on page 7.

The communication protocol used between our senders and displays is proprietary allowing us to control the accuracy and functionality of our systems ensuring our customers experience reliable operation.

The 708-RBT Soul module should be installed before senders are mounted.

All documentation can be found from the **Resource Library** found on our support page: <https://www.garnetstruments.com/support/>

Before installing
senders watch
this video!



SCAN TO WATCH

DETERMINE BEST PLACEMENT & CONFIGURATION

Sender Placement

The senders will need to have a flat area on the side of the tank large enough so the whole width of the sender is in contact with the side of the tank.

Make sure that any metal is at least 1" away from either side, top and bottom of the sender, and at least 2" away from the face of the sender.

Some tanks may have irregular shapes. DO NOT wrap the corners over the top or bottom of the tank.

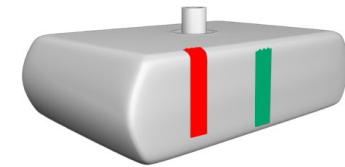

INCORRECT
CORRECT

See placement examples to the right.

CAUTION: Bending the sender sharply will damage the circuit on the sender.



INCORRECT
CORRECT

Sender Configuration

To determine which sender configuration you need, measure the height of your tanks, then find out the measurable space (*see following page*). The measurable space is the "ideal" position of the sender on the tank. This will determine what length the senders should be. If a sender is too long, it will need to be cut. The following table has recommended senders and configurations for various tank heights.

Recommended Sender Options

Tank Height	Best Sender Option
3.5" - 11"	710-AR2 single
11" - 14"	710-ES3 single
14" - 18"	710-SS2 single
18" - 20"	710-AR2, stacked
18" - 26"	710-ES3, stacked
26" - 34"	710-SS2, stacked

CAUTION: DO NOT mix sender types when stacking senders.

DETERMINE MEASURABLE SPACE ON TANKS

Find Measurable Space

Measure the height of the tank from top to bottom then determine measurable space.

- The minimum gap is 1/4", however, we recommend that the senders be installed 1/2" from the top and 1/2" from the bottom of the tank. Depending on the characteristics of the tank the gap can be a little more or less (see note below and installation tips on page 11). This gap ensures that the sender can read properly through the tank wall as the corners or rounded edges of the tanks can be too thick for the sender to read through.
- Subtract the gap space from the overall tank height. This will result in your measurable space. Use the calculation formula at the right.

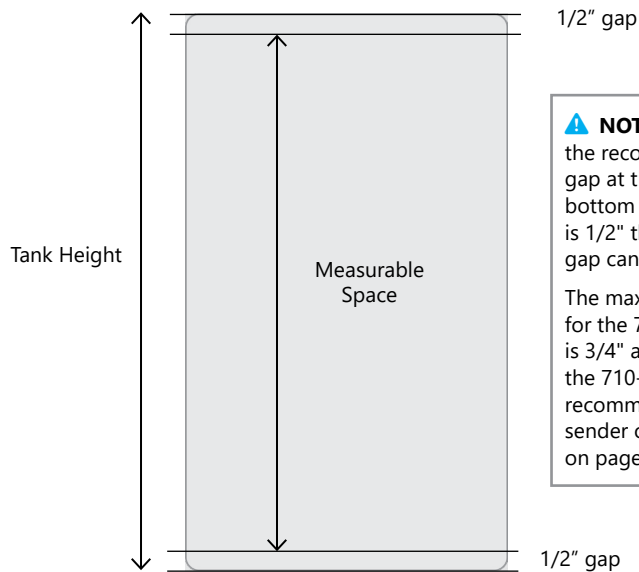

NOTE: Although the recommended gap at the top and bottom of the tank is 1/2" the minimum gap can be 1/4".

The maximum gap for the 710-AR2 is 3/4" and 1" for the 710-ES3. See recommended sender options table on page 2.

CAUTION: Installing a sender outside of the recommended measurable space may affect your readings.

NOTE: This is not a static formula that can be used on every tank. With some fresh tanks, the outlet for the pump feed may sit more than 1 inch above the bottom of the tank. Your water pump may begin to suck air before the tank is completely empty. In these cases, you want to install the fresh tank sender above the outlet for the pump feed. This will ensure that the monitor reads "0" before the pump begins to suck air.

Single configuration

- Measure the height of the tank.
- Tank height = _____
- Calculate the recommended measurable space as follows:

$$\text{Tank height} - \text{top gap} - \text{bottom gap} = \text{measurable space.}$$
**See note regarding gap recommendations.*

NOTE: If senders do not fit full height of the tank, to optimize the level you can justify sender location to be either closer to the top or bottom, depending on the type of liquid (Fresh or Grey/Black).

FRESH = closer to bottom as it is preferable that this tank is not empty!

GREY/BLACK = closer to top as it is preferable that these tanks are not full!

Stacked configuration

Two senders may be required for taller tanks and additional senders may be purchased for this application. There needs to be a gap of 1/16" to 1/8" between the double stacked senders. Calculate what the total length of measurable space for both senders will be:

- Measure the height of the tank.
- Tank height = _____
- Calculate the recommended measurable space
- $$\text{Tank height} - \text{top gap} - \text{bottom gap} - \text{middle gap} = \text{measurable space.}$$
**See note regarding gap recommendations.*

NOTE: Both senders in a double-stacked configuration should be approximately the same length.

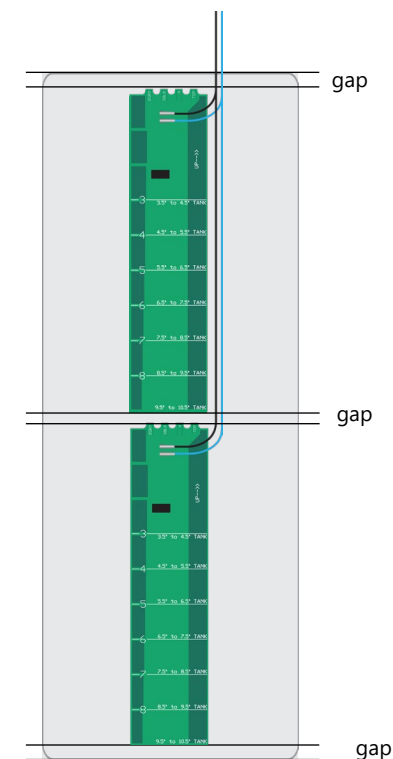
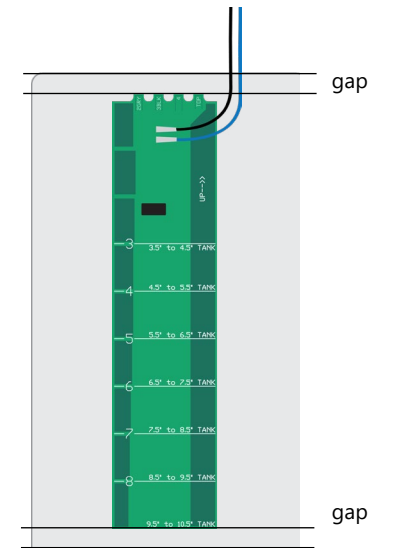

SENDER SPECIFICATIONS

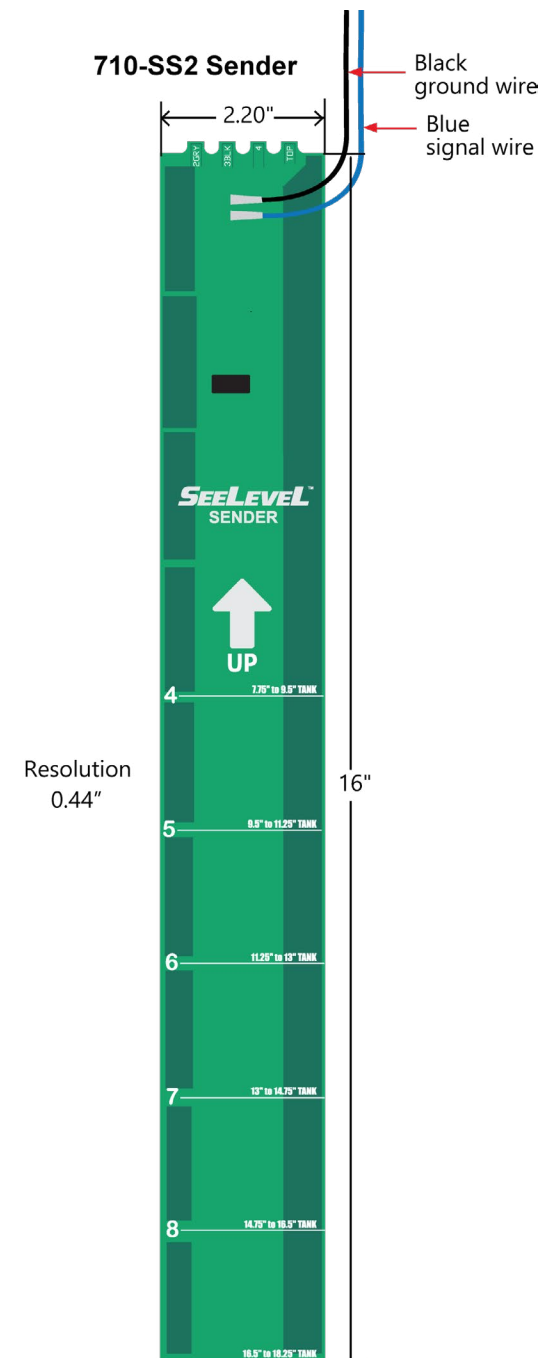
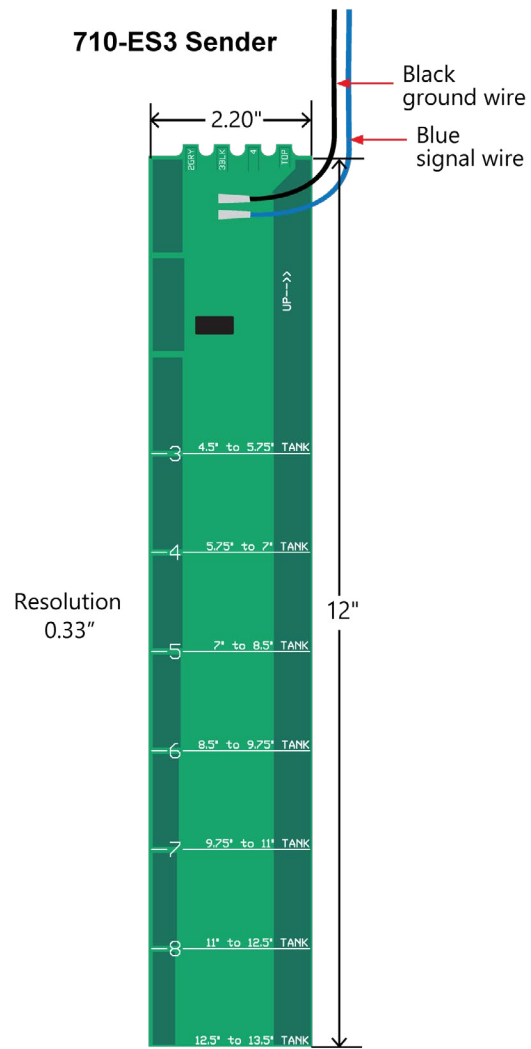
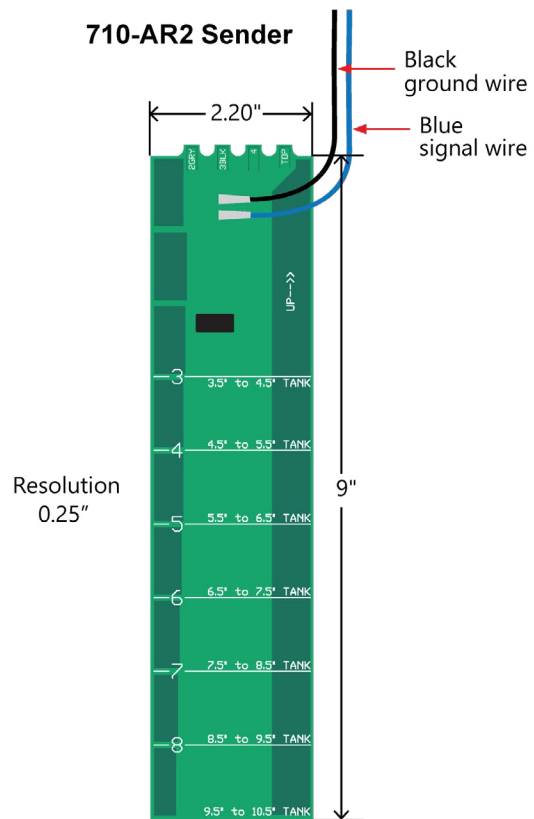

CUTTING SENDERS

The senders need to be cut to the required length to match the height of the measurable space of the tank.

The cut must be between the sender segmented pads. Senders have a minimum length they can be cut. The minimum length is after the first three segmented pads.

Once this has been determined, cut the sender with a pair of scissors.

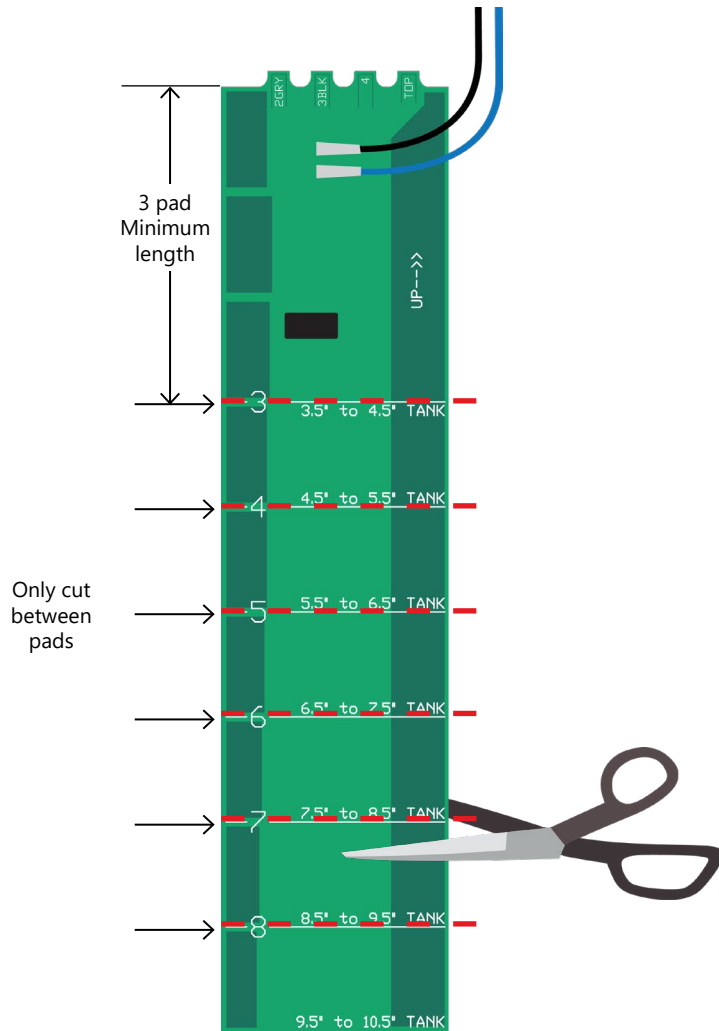

PROGRAMMING THE SENDERS

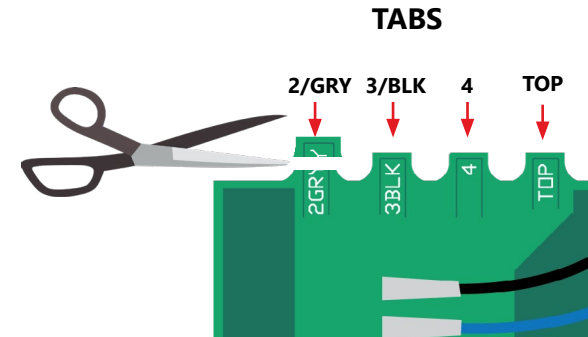

Senders are programmed by cutting off the tabs at the top of each sender to tell it which tank it will be mounted on, or if in a stacked configuration, whether they are on the top or bottom. A pair of scissors or a hole punch can be used to cut the sender tabs.

For tanks 5 through 7, use the sum of two tab numbers for that tank number. This will only work on display models that can read up to 7 tanks.

For examples of programming for each tank types refer to the table at the bottom and the illustrations on the next page.

TANK TYPE	TABS TO CUT
FRESH	No tab cut
GREY	2GRY
BLACK	3BLK
FRESH 2 (TANK 4)	4 (For 709-BTP7 & 708-RBT Soul only)
GREY 2 (TANK 5)	2GRY + 3BLK (For 709-BTP7 & 708-RBT Soul only)
BLACK 2 (TANK 6)	2GRY + 4 (For 709-BTP7 & 708-RBT Soul only)
GREY 3 (TANK 7)	3BLK + 4 (For 709-BTP7 & 708-RBT Soul only)
GALLEY (only for displays with a GALLEY button)	2GRY + TOP (For 709-4P, 709-4LP 709-4PH only)
TOP Sender	Cut "TOP" tab + tank type tab

⚠ CAUTION: MAKE SURE YOU CUT THE CORRECT TABS! Cutting the wrong tabs will result in incorrect programming and this cannot be reversed and is not covered under warranty

Tabs to cut for single sender or bottom sender if double-stacked.

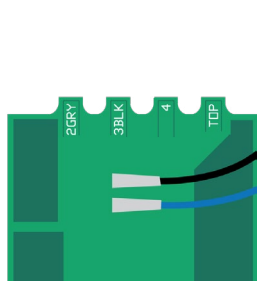

FRESH

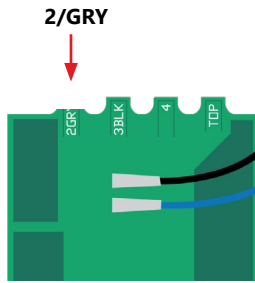

GREY

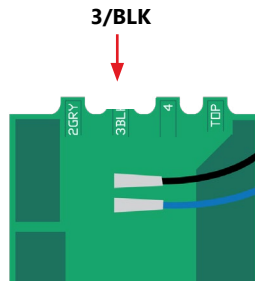

BLACK

NOTE: Previous model senders (710-JS, 710-ES, 710-ES2, 710-SS) can be combined with new sender models.

NOTE: For systems that have a **Galley button**. Cut the 2/GRY and the TOP tabs. For displays that have a GALLEY button the GREY and GALLEY tanks can only have one sender per tank and cannot be stacked.

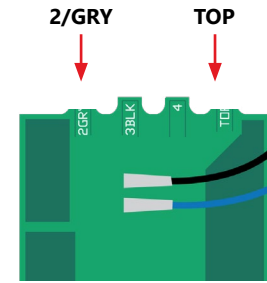

GALLEY

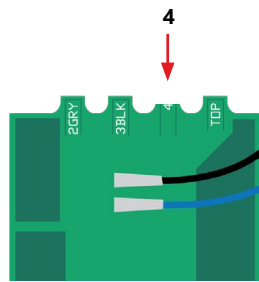

**FRESH 2
(TANK 4)**

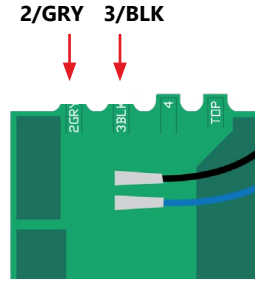

**GREY 2
(TANK 5)**

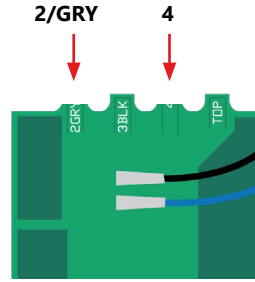

**BLACK 2
(TANK 6)**

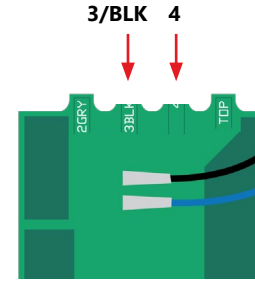

**GREY 3
(TANK 7)**

CAUTION: MAKE SURE YOU CUT THE CORRECT TABS! Cutting the wrong tabs will result in incorrect programming and this cannot be reversed and is not covered under warranty

NOTE: For tanks 5 through 7, use the sum of two tab numbers for that tank number. This will only work on models that can read up to 7 tanks.

For a double-stacked tank configuration, the top sender requires an additional tab to be cut.

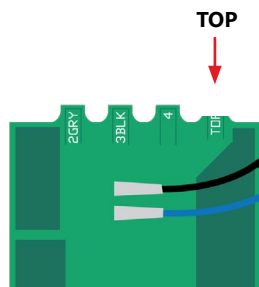

FRESH TOP

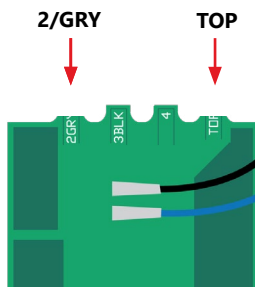

GREY TOP

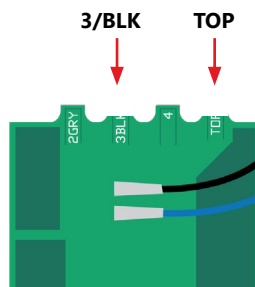

BLACK TOP

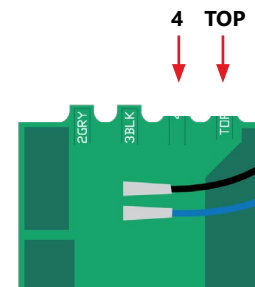

**FRESH 2 TOP
(TANK 4)**

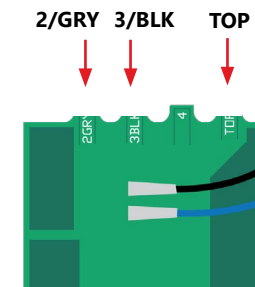

**GREY 2 TOP
(TANK 5)**

For Tanks 4 - 7 also cut the TOP tab as these examples indicate.

PREPARE SENDER FOR INSTALLATION

1 Clean the tank

Clean area thoroughly where the sender will be mounted making sure there is no dust, grease or oil.

Acetone or rubbing alcohol will remove sticky residue.



2 Temporarily tape sender on tank

CAUTION: DO NOT SKIP THE FOLLOWING STEPS. Removing the sender from the tank after the sender has been permanently installed will cause damage to the sender that is NOT covered under warranty.

Once the sender is cut and programmed, temporarily tape the sender to the tank wall. Place a piece along the length of both sides of the sender and perform a test to verify operation.

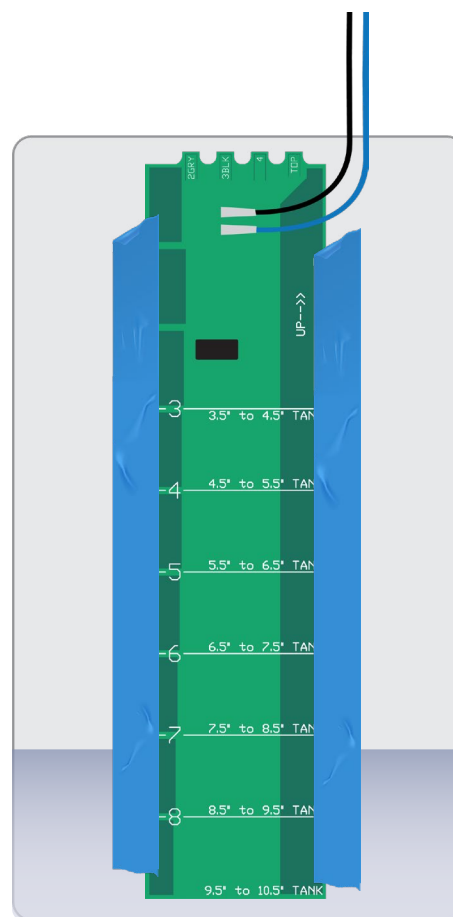

CAUTION: Route wires to the right, away from the senders. The wires indicate the top of the sender.



Use a non aggressive tape like painters tape or masking tape.

3 Connect the wiring to the pigtail

The following diagram shows the wiring from the sender to the pigtail. Other wiring connections may apply for each model. All wiring diagrams are available on the website.

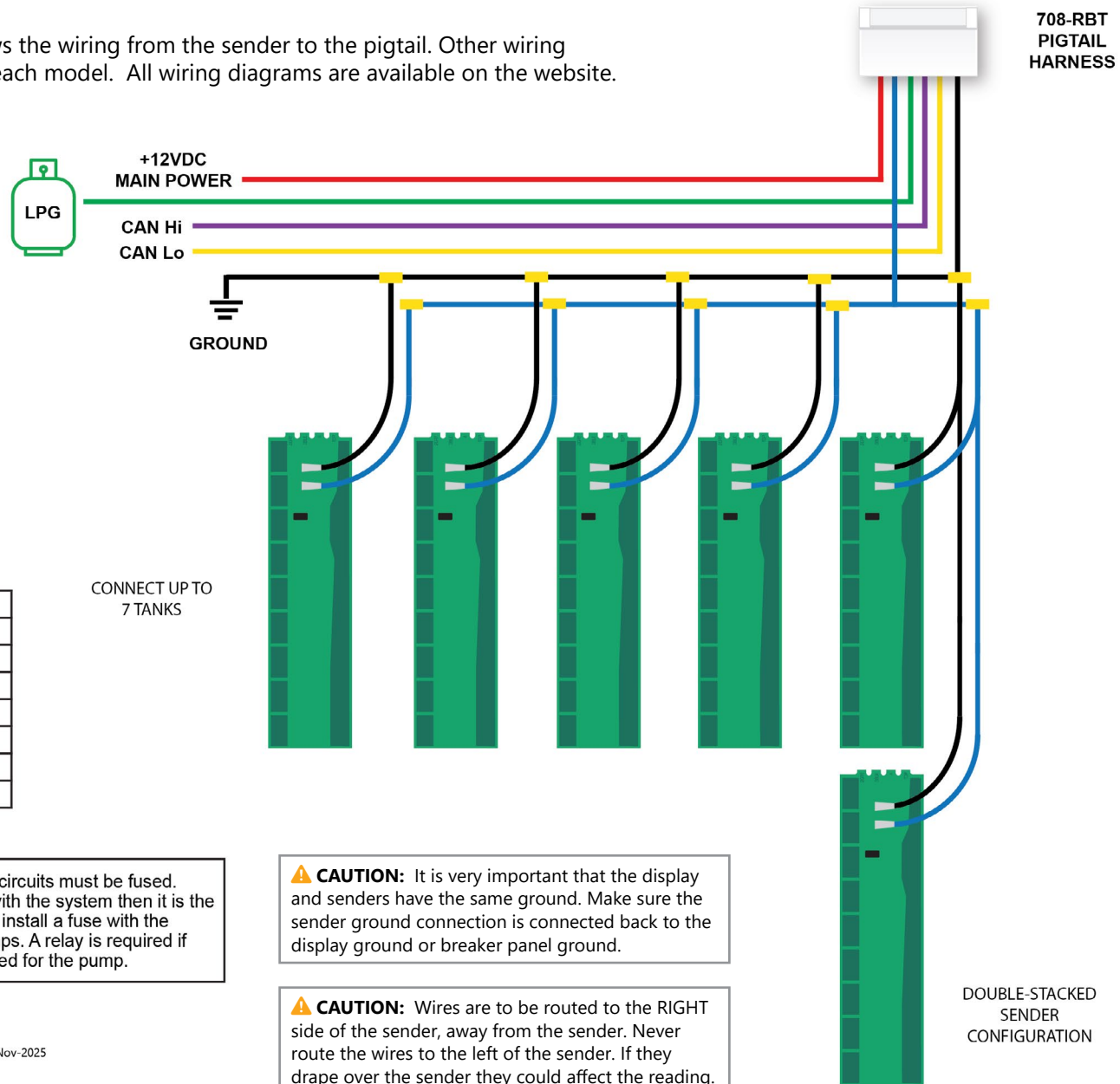

Pigtail Wires

Pin	Color	Function
1	Red	Power +12V
2	Blue	Senders
3	Green	LPG Tank
4	Purple	CAN-Hi
5	Yellow	CAN-Lo
6	Black	Ground
7	-	-

⚠ WARNING: All power circuits must be fused. If a fuse is not provided with the system then it is the installer's responsibility to install a fuse with the maximum rating of 7.5 amps. A relay is required if more than 7.5 amps needed for the pump.

⚠ CAUTION: It is very important that the display and senders have the same ground. Make sure the sender ground connection is connected back to the display ground or breaker panel ground.

⚠ CAUTION: Wires are to be routed to the RIGHT side of the sender, away from the sender. Never route the wires to the left of the sender. If they drape over the sender they could affect the reading.

4 Verify operation before permanently adhering the sender to the tank.

NOTE: The display needs to be installed and power supplied before the sender operation can be verified. Once verified, sender is ready to be permanently mounted.

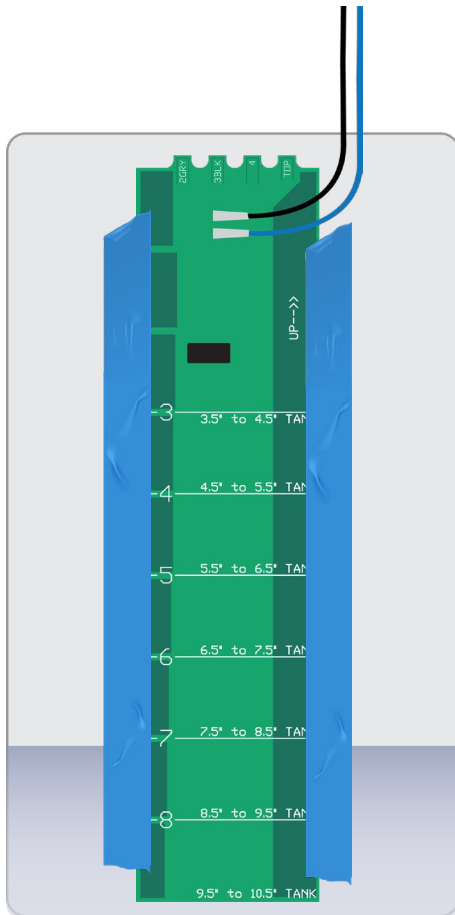

Tank levels operation test

For the initial test, have the tank at least 1/4 full of water or sewage.

Verify that the percent level reading on the display panel looks correct.



FRESH

25

LEVEL IN PERCENT



Signal strength test

The signal power is an indication of how much signal is being transmitted through the tank wall and picked up by the receiver part of the sender.

MOUNTING THE SENDERS

5 Permanently adhere sender to the tank

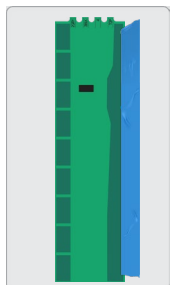

Once proper operation has been confirmed, the sender will be ready to be permanently installed to the tank wall.

Remove one side of the tape.

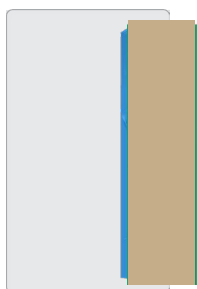

Fold the sender over so it is still attached with one side of the tape.

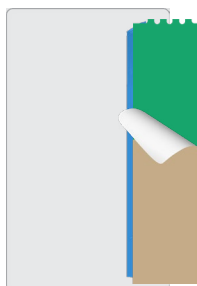

Slowly peel the backing paper off the adhesive.

CAUTION: Be careful not to bend the senders excessively or you could damage the circuits. You only have one shot at this. If you try to peel it off the tank once it is stuck the sender may be damaged by the sharp bending. Removing the sender after it's been adhered voids the warranty.

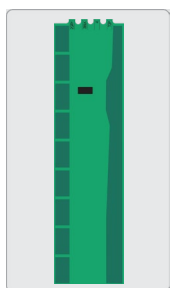

Carefully fold the sender back and press the sender down to the tank so that all of the adhesive is contacting the tank wall. Make sure there are no air gaps between the sender and the tank. Remove the other side of the temporary tape.

6 Secure the wires

Secure the wires with duct tape, tie wraps, or something similar so that the wires do not rattle or press against the sender, this may result in sender damage or wires breaking over time.

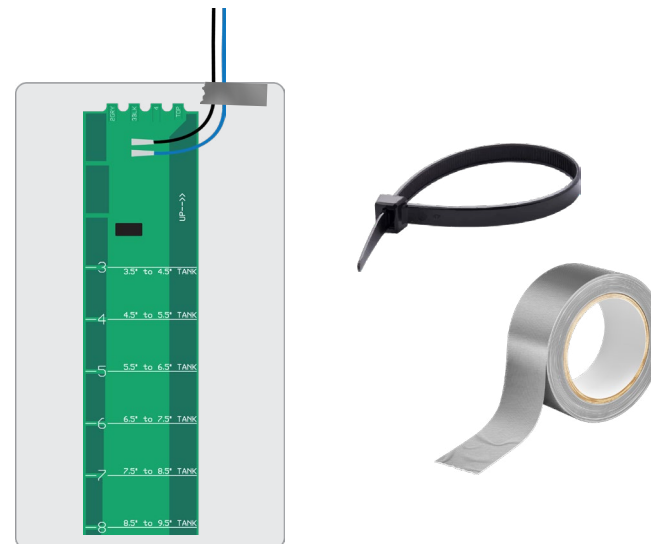

7 Apply undercoating to the senders

On installations where the holding tank is exposed to under chassis road spray and flying rocks etc. the installer must use added protection. We suggest:

Gorilla Waterproof Patch & Seal Tape

3M 03584 Professional Grade Rubberized Undercoating

Gravel Guard Rocker Guard Coating By Dominion Sure Seal

MODULE INSTALLATION

The installation involves mounting the 708-RBT Soul module and installing the senders on the sides of the holding tanks. The senders may be cut to fit your tank. It is recommend to use crimped butt connectors to connect the wiring harness, or solder the wires directly and protect with heat shrink tubing.

Module Diagram

This drawing of the module gives dimension data of the device enclosure to be used for locating the holes for mounting screws onto the wall (**Note:** diagram not to scale).

Connect the wiring according to the table on the following page. It is easier to connect the wiring to the 708-RBT Soul Module pigtail first, and then plug the connector into the 708-RBT Soul Module. For best results, ensure that the Senders use the same electrical ground wire as the 708-RBT Soul's power source.

⚠ CAUTION: Please refer to the "TROUBLESHOOTING AND INSTALLATION TIPS" section for details on avoiding installation issues.

⚠ WARNING: All power circuits must be fused. If a fuse is not provided with the system then it is the installer's responsibility to install a fuse with the maximum rating your model requires.

A relay may be required for models with a pump or heater switch.

For information about the requirements for your model please refer to the specifications page and wiring diagram.

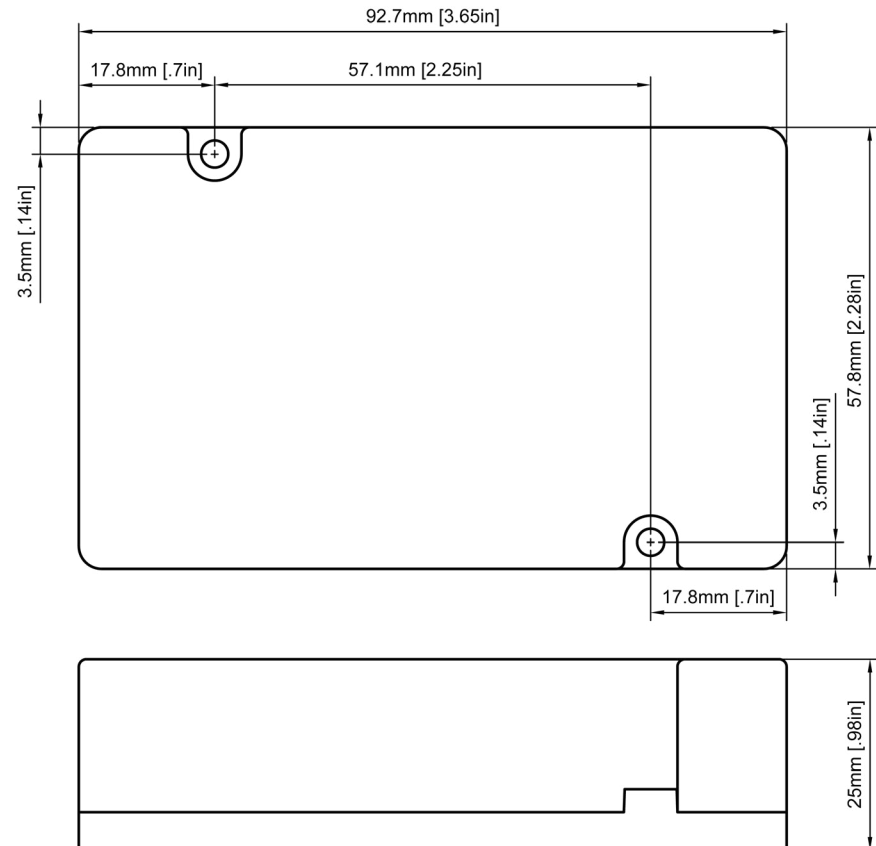

RV-C Diagnostics

Listed below are the error messages broadcast over the RV-C bus:

FMI (Failure Mode Identifier)				
Error ID	RV-C Protocol Error Description	708-RBT Soul internal Error Description	Possible cause	Suggested Solution
0	Datum value above normal range	Nbo. No Bottom Sender	No bottom sender. 708-RBT Soul has been programmed for double-stacked senders and one of these error codes are showing: but only the top sender is working, and the bottom sender is not.	Correct the programming on the sender.
1	Datum value below normal range	ntP. No Top Sender	<u>No Top Sender.</u> No bottom sender. 708-RBT Soul has been programmed for double-stacked senders and one of these error codes are showing: but only the bottom sender is working, and the top sender is not.	Correct the programming on the sender.
2	Datum value erratic or invalid	Err. Sender sending bad data.	1. Senders have not been programmed correctly. 2. The sender is sending bad data. 3. There is damaged wiring. 4. There is electrical interference.	Check all the senders to make sure they are programmed correctly. If they are, replace the sender that is creating the error.
5	Open circuit, or output current below normal	Opn. Sender is not sending data	1. A sender is unresponsive. 2. There is an open circuit in the wiring, so the sender is not connected.	Check sender wiring or replace unresponsive sender.
6	Grounded circuit, or output current above normal	Sht.	A sender is shorted or there is a short in the wiring.	Check sender wiring or replace shorted sender.
13	Calibration required (only for LPG tanks)	CAL.	LPG tank level sensor needs to be calibrated by 708-RBT Soul input circuit.	Calibrate LPG tank
15	Datum valid but above normal operational range (least severe)	StA. stacked error	Soul has been programmed for a single sender where double-stacked senders have been connected. Soul has not been set to look for two senders.	Correct Soul configuration programming or disconnect top sender.

Single Diagnostic LED patterns

The 708-RBT Soul has two diagnostic LEDs designed for different purposes:

RED DIAGNOSTIC LIGHT PATTERNS		
Status	Description	LED blinking pattern
NORMAL Operation. (Soul is configured to handle, at least, one water/waste Tank and the SENDER for this tank is properly configured and connected to Soul)	No wiring error detected in SENDER'S circuit or in the RV-C connections	One blink per second.
SENDER wiring Error	A sender may be in open circuit or short circuit state, or more than one sender is not correctly configured.	Two consecutive blinks.
RV-C wiring Error	Soul is not connected to RV-C network or RV-C network is missing the termination resistor	Three consecutive blinks.
SENDER wiring Error and RV-C wiring Error	Compounded error. Both SENDER wiring Error and RV-C wiring Error are happening.	Four consecutive blinks.
GREEN DIAGNOSTIC LIGHT PATTERNS		
Status	Description	LED blinking pattern
NORMAL	No bluetooth connection	1 blink per second
BLE connection active	Actively connected through Bluetooth. Note! The SeeLevel RV monitoring app will access information without forming a connection (See appendix A - BLE info). A connection is formed when connected through the SeeLevel Launch app for configuration.	Rapid Blinking

GREEN LED RED LED

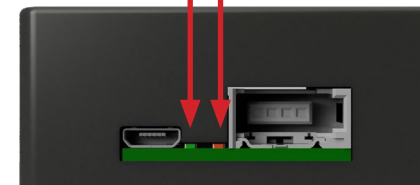

Wiring Diagnostics Flowcharts

OPEN CIRCUIT WIRING DIAGNOSTICS

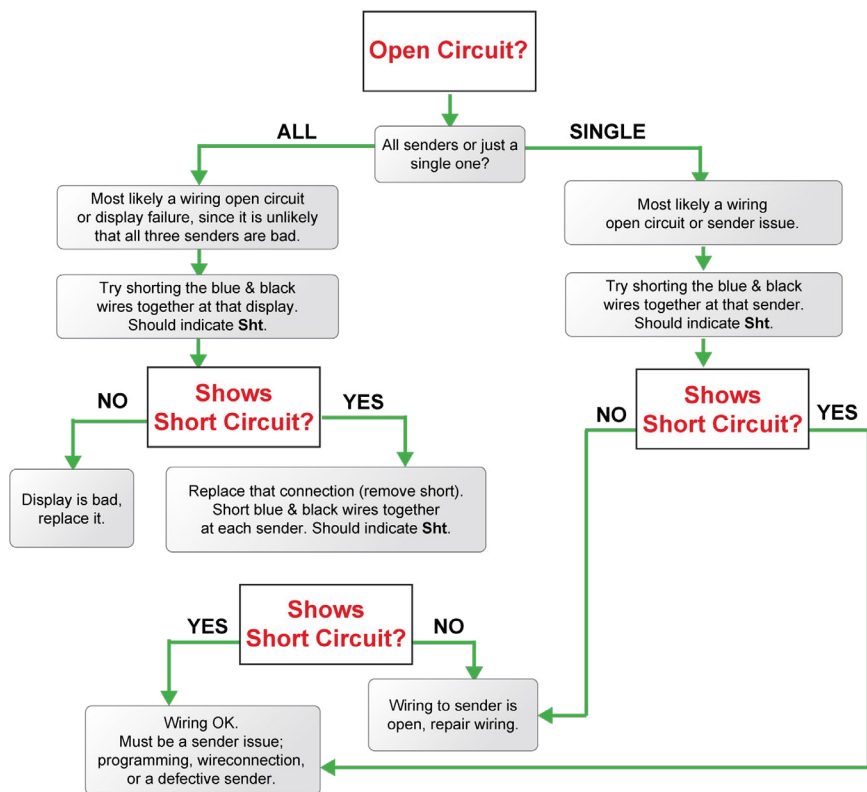

SHORT CIRCUIT WIRING DIAGNOSTICS

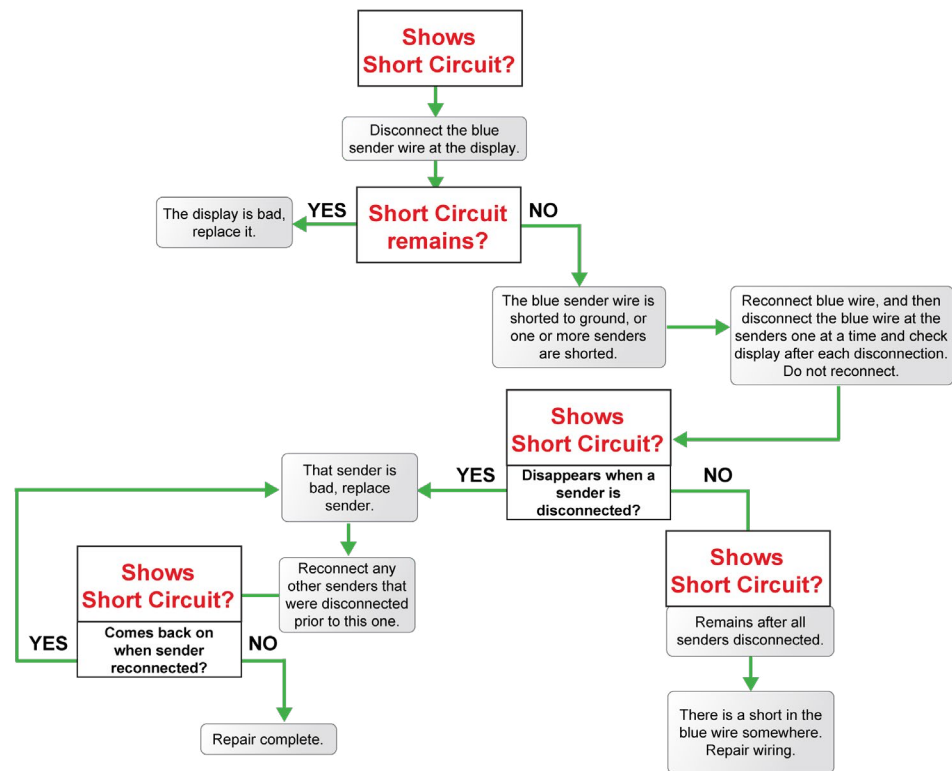

Troubleshooting & Installation Tips

What to do if the system freezes or is unresponsive

If the 708-RBT Soul Module is unresponsive, try rebooting it by shutting off the 12V power for 10 seconds and turning it back on.

What to do if operation becomes erratic or stops completely

Ensure that there are no unexpected breaks in the wiring to the 708-RBT Soul. We recommend insulated crimp-on butt connectors or soldering the wires and insulating with heat shrink.

What to do if readings jump or are inaccurate

1. We have had a few instances where 120VAC interference has caused the readings to stall and create a gap; readings would skip from 50% to 70% and then begin to function again. The cause was wiring between consoles and senders being tied too close to entrance boxes for shore power or bundled with other high AC voltage lines or junction boxes.
2. Always ground the senders and the console to the same ground circuit. This is very important; RV's can have several ground circuits with resistance between them. We have had instances where two consoles are installed with a different ground for the service bay console and interior console. If you see different levels from each console on the same tank, then the ground circuit is not common. Connect both consoles to the same ground back to the breaker panel ground point.

What to do if the system indicates a residual or non-zero water level even though the tank is drained completely

1. This can be due to a convex tank bottom or a sloped tank bottom. In the case of the convex bottom tank, a ring of water may remain after draining. In the case of the sloped bottom (to the drain valve side) a very small amount of water left in the tank will result in a non-zero level indication. In both of these cases, temporary installation of the sender using duct tape or masking tape will allow the installer to check the tank level before committing to a final sender position. After cutting the sender to length and connecting the wires, be sure to tape down both sides of the sender to eliminate air gaps between the sender and tank surface which can cause low signal strength and unpredictable performance. The ends of the sender must be at least ¼" to ½" away from the tank bottom and top to allow for wall thickness. The exterior bottom & top of the tank are not the same as the interior bottom & top; depending on the tank wall thickness the inside height is ½" to 1" shorter than the outside height. Knowing the wall thickness of your tank will allow you to find the optimal sender position; placing the sender where it can "see" the water will ensure proper level calculation and sender operation.
2. The signal strength should be in the 50% range for best performance. If the signal strength is in the 20% range it is indicative of a high resistance in a connector, a bad ground, or improper bonding of the sender to the tank (a possible air gap on one or both sides of the sender).

3. With the console installed you can check the level on each tank, if you get an indicated level of 10% to 20% and you know this is too high, reposition the sensor board as follows:

▲ NOTE: In the case of a convex tank bottom, usually found on large flat tanks, raising the sender is the best solution to accomplish a zero reading when the tank is empty. This may result in having to shorten the sender by an additional segment.

On sloped tanks, which are used to promote complete draining, one alternative is to measure the end of the tank opposite from the drain valve. It may be necessary to extend the wire harness to be able to measure on the optimal side. On the drain valve side, the best choice is to elevate the sender to avoid reading a puddle at the drain valve.

4. The close proximity of metal to the sender can be misinterpreted as water since they have similar electrical characteristics. Any metal such as steel, aluminum, copper, or brass can affect the sender reading if it is closer than about 2" from the face of the sender. If there are metal frame pieces, brackets, straps, pipes, ducts, etc. close to the sender you may have to move the sender away from them. Again, trial positioning using tape is necessary until the problem disappears. Flexible pieces of metal can be held away from the sender with rubber wedged between the sender and the metal. If the metal is off to the side of the sender, or just butting to the edge then it is usually not a problem, particularly on the right-hand side of the sender.
5. Make sure that metal doors or covers are far enough away from the sender as well, once everything is closed up the positioning may change. The symptoms of exposure to large metal components are usually a non-zero reading when the tank is empty, or the level appearing to jump suddenly as the tank is drained or filled.
6. On fresh tanks there is sometimes a potential to not be able to use all the water in the tank, we suggest you elevate the fresh sender 1" off the tank bottom and position the top of the sender to allow for vent position (if the vent is on the side of the tank). This way you should see '0' before the pump starts to suck air. Some tanks have a sump style draw system, in this case, there is no concern with unusable water, just allow for the wall thickness when positioning the sender board (usually ½" to 1" margin from the outer shell). If the sender is positioned above the vent then the maximum reading may be less than 100%.
7. There may be a buildup on the inside walls of black and grey tanks. We get calls occasionally about older coaches that have not been in service for a few years in which the black tank will now indicate a level even though it is empty. The likely cause is that the tank has a significant build-up, probably exceeding ¼" to ½" thick! Redex is not an acceptable chemical to promote clean tank walls; it is far too slow to get the breakdown action started. Use an RV type of liquid chemical, we suggest Tissue Digester, Sensor Cleaner, or the latest we have used called Happy Campers Holding Tank Extreme Cleaner available at happycampersworld.com. The next time you take a trip, leave with a high concentration of the chemical in the tank and approximately 30% full of fresh water. Hopefully you can drive for 2-3 days allowing the tank levels to rise through normal use. We recommend that

you exceed the level that you see the system report when the tank is empty. After the sloshing and the soaking hopefully the build-up will be flushed away when the tank is drained and flushed. If you still have symptoms the treatment may be required a few more times. The waste did not build up on the tank wall in one day, so it may not dissolve in one treatment! The build-up looks like water to the system since it holds a significant volume of water in the build-up area. It takes much more than a film or piece of tissue to cause the error.

What to do if the system reads a zero water level at all times, or does not reach 100%

1. This may be due to excessive tank wall thickness. We have tested the sender on an actual tank with $\frac{3}{8}$ " wall thickness to ensure proper operation. If you encounter an excessively thick tank wall the symptom will be a zero reading regardless of the actual tank level. The crosscheck would be to test the sender on another tank by taping it in place temporarily, if it now works the tank wall thickness is well over $\frac{3}{8}$ ". You can also use a 1 gallon jug or a 5 gallon pail as a test tank to crosscheck operation of the sender.
2. A symptom we have seen is the sender will not indicate 100% when the tank is full. If the sender is positioned too high on the tank, then water cannot reach high enough on the sender for it to read 100%. The top of the sender must be at least $\frac{1}{4}$ " to $\frac{1}{2}$ " away from the top of the tank to allow for wall thickness.
3. Another possibility is a tank wall thickness issue that may occur at the corners or edges of the tank. This has not been a common issue, and the only correction you can make is to move the board slightly lower, away from the thick area.

What to do if sender delamination occurs

1. We have had reports of the senders literally falling off the tanks or showing serious delamination. This is likely caused by a lack of tank surface preparation. Surface prep is very simple, wipe the area to be adhered to with products like Pro Bond, alcohol, or acetone. Do not use thinners because they leave residues that attack the adhesive. Ambient temperatures of less than 60°F or 15°C prevent the bonding agents in the adhesive from working properly; use a heat gun to warm the tank surface if necessary. Also, be sure the surface is dry, again a heat gun is the best way to dry the bonding area. Finally, the surface of the tank must be smooth. The adhesive works much better on smooth surfaces, if necessary use an orbital sander with fine grit paper (220 grit) to quickly accomplish the desired smoothness.
2. Another possibility is the wiring harness pulling on the sender. Make sure the wiring to the tank sender is well supported so that it does not put a load on the sender. Be sure to support all connecting harnesses; do not let the board support the harness, this will in time cause delamination of the board from the tank. One simple way to do this is to use Gorilla tape across the top of the sender at a 90-degree angle to the sender orientation, with the wiring held in place by the tape. The wires from the sender must be routed straight up or to the right for reliable operation.

How to protect the sender from road spray and debris

1. On installations where the holding tank is exposed to under chassis road spray and flying rocks etc., we recommend the use of an auto body undercoat, which is easily purchased in auto parts stores. This tar-based material clings well to the senders and protects from water and debris.
2. One material, in particular, is 3M Professional Grade Rubberized Undercoating, product code 03584. Another product that works well is a Dominion Sure Seal rubberized undercoating such as Gravel Guard Rocker Guard Coating, as well as Gorilla Waterproof Patch & Seal tape.
3. After the system is completed and tested apply the undercoat over the complete board using two coats. Do not use lacquer, enamel paint, or plastic paint for auto bumpers as these contain chemicals that will dissolve the conformal coating on the board and cause malfunctions.

WARRANTY & SERVICE INFORMATION

For complete warranty information please visit our Support page. If you do have a warranty claim or if the equipment needs to be services please contact the installation dealer.

www.garnetinstruments.com/support/

If you do need to contact Garnet we can be reached as follows:

CANADA

Garnet Instruments
286 Kaska Road
Sherwood Park, AB T8A 4G7
CANADA
email: info@garnetinstruments.com

UNITED STATES

Garnet US Inc.
5360 Old Granbury Road
Granbury, TX 76049
USA
email: infous@garnetinstruments.com

SPECIFICATIONS

708-RBT Soul Module:	Size: 3.6" wide x 2.3" high x 0.98" deep (91.4 mm wide x 58.4 mm high x 25 mm deep) Enclosure mounts to the wall with screws.
System power requirements:	Data Module requires 12 volts from the RV battery, the system will function from 11 volts to 16 volts. Current drain is less than 200mA.
Wiring:	A single two-wire conductor required from the 708-RBT Soul Module to the senders. All the senders are wired in parallel. 12 V power and ground required for the 708-RBT Soul Module. A separate two-wire conductor required from the 708-RBT Soul Module to the LPG sender.
LPG:	The 708-RBT Soul Module will work with an LPG sender with a maximum resistance of 10 ohms to 250 ohms. The 708-RBT Soul Module shows increasing level as resistance increases. System must be calibrated with the LPG tank full.
Compliance and Certifications:	CAN ICES-003(B)/NMB-003(B) This device complies with part 15 of the FCC Rules. Operation is subject to the following two conditions: (1) This device may not cause harmful interference, and (2) this device must accept any interference received, including interference that may cause undesired operation. Contains FCC ID: FCC ID: 2AC7Z-ESPC3MINI1 Contains IC: 21098-ESPC3MINI1 Changes or modifications not expressly approved by the party responsible for compliance could void the user's authority to operate the equipment.
Warnings:	WARNING: This product can expose you to chemicals including Nickel and Lead, which are known to the State of California to cause cancer, and lead which is known to the State of California to cause birth defects or other reproductive harm. For more information go to www.P65Warnings.ca.gov . All power circuits must be fused. If a fuse is not provided with the system then it is the installer's responsibility to install a fuse. The fuse rating must be 7.5 amps for the display. For more detailed information please refer to " TROUBLESHOOTING GUIDE " and section "How to avoid damaging the display or pump switch due to excessive current".

APPENDIX A

Bluetooth Information

The 709-RBT utilizes Bluetooth Low Energy (BLE) to broadcast data packets every two seconds. This connectionless advertising allows any nearby gateway or receiver to capture data without manual pairing; the payload specifications below are provided to help you decode this data for custom integrations.

SeeLevel Standardized BLE Broadcast Map

Device Name: G709, Soul G708

Company ID: 0x0CCC0

Manufacturer Data

Byte 0	Byte 1	Byte 2	Byte 3	Byte 4	Byte 5	Byte 6
Serial Number			Fresh 1	Grey 1	Black 1	Fresh 2
Byte 7	Byte 8	Byte 9	Byte 10	Byte 11	Byte 12	Byte 13
Grey 2	Black 2	Galley	LPG	BATT	FutureUse	FutureUse

Serial Number:

24bit little endian number

TANKS		
Fresh1	Level 0 to 100%. Any value above 100 is an exception, see exception list.	ShortCircuit = 101,
Grey1		Open = 102,
Black1		BitCounterError = 103,
Fresh2		StackMisconfig = 104,
Grey2		MissingTop = 105,
Black2		MissingBottom = 106,
Galley		NoCalibration = 107
LPG		BadChecksum = 108,
	OutOfRange = 109,	
	Disabled = 110	
	Ini = 111,	
	BadID = 112,	

Battery: Battery *100

APPENDIX B

RV-C Data FAQ

The 708-RBT Soul transmits data over CAN according to the RV Industry Association's RV-C standard. It integrates seamlessly with any RV-C capable device. A number of common questions are answered here:

The subset of RV-C protocol DGNs (Data Group Number) that 708-RBT Soul supports is described in the following list.

Data Group Numbers (DGNs)
PRODUCT_ID
TANK_STATUS
DM_RV
ADDRESS_REQUEST
ADDRESS_CLAIM
DGN_REQUEST
NACK
INITIAL_PACKET
DATA_PACKET

For more information on each DGN, please consult the official RV-C documentation from the RV Industry Association.

When does 708-RBT Soul negotiate a source address?

1. Whenever 708-RBT is powered
2. Whenever another device connects to the same network as 708-RBT Soul, and if that other device is claiming the same source address that Soul has claimed for itself

What is the procedure and which DGNs does 708-RBT Soul use when it negotiates a new address?

The RV-C node dynamically requesting a source address begins with an address request message. Every RV-C node in the network shall be able to respond to the address request message with an address-claimed message. A dynamically addressed RV-C node will try addresses until it finds one unclaimed. Once it finds an unclaimed address, it sends the address.

What is the bit rate of the CAN bus?

250 kbps