

SEELEVEL SPECIAL™

TANK LEVEL GAUGE FOR TRUCKS Installation & Operation Guide



808-P2



810-X



810-TX

Printed in Canada

CANADA
Garnet Instruments Ltd.
286 Kaska Road
Sherwood Park, AB T8A 4G7

USA
Garnet US Inc.
5360 Old Granbury Road
Granbury, TX 76049

GARNET
Liquid management solutions, your way.

garnetinstruments.com
1-800-617-7384

TABLE OF CONTENTS

Select an item from list below to go to that page.

1.0 INTRODUCTION	3
1.1 Overview.....	3
1.2 Features and Benefits.....	3
2.0 QUICK GUIDE	4
2.1 Operation.....	4
2.1.1 Alarms.....	4
2.2 View Firmware Revision, Mode and Temperature (Rev M).....	5
3.0 INSTALLATION GUIDE	6
3.1 Sender Bar Assembly.....	6
3.2 Tank Preparation	7
3.2.1 Determine sender bar mounting position	7
3.2.2 Install NPT Collar and Float Support.....	7
3.2.3 Cutting the Bar.....	8
3.2.4 Sender Bar Installation.....	8
3.3 Mount the Display.....	8
3.3.5 Connect the Airline Hose.....	10
3.4 Install Fiber Optic Cable	11
3.4.1 Preparation of Fiber Optic Cable	11
3.4.2 Connect the Fiber to Display Enclosure	11
3.4.3 Plug Fiber to the Receiver Connector	11
3.4.4 Connect Fiber Optic Cable to Sender Bar Head.....	11
3.4.5 Install Airline on the Truck	12
3.5 Program the Display	12
3.5.6 Verification of Bar Operation.....	12
3.6 Wiring Diagrams	14
3.6.1 Common Configuration	14
4.0 MAINTENANCE AND SERVICE INFORMATION	15
4.1 O-Ring.....	15
4.2 Brass Fitting.....	15
4.3 Cleaning Display.....	15
4.4 1/4" Airline.....	15
5.0 TROUBLESHOOTING GUIDE	16
5.1 Diagnostic Flowchart.....	16
5.2 FAQs.....	16
5.2.1 Why does my display read "No L".....	16
5.2.2 Why does my display read "bL" and then a number?	16
5.2.3 Why does my display read "Sun".....	16
5.2.4 Why is my display blank?.....	16
5.2.5 Why does the reading jump around when the tank is being filled?.....	16
5.2.6 Why does my display seem to be stuck on a number?	16
5.2.7 How to contact service?	16
6.0 SYSTEM SPECIFICATIONS	17
6.1 Parts List for Installation.....	18
6.2 Safety Information.....	19
6.3 Warnings and Cautions	19
6.4 Notice of Limited Liability.....	19
7.0 WARRANTY	20

2026 Garnet Instruments. All rights reserved. No part of this publication may be reproduced, Transmitted, transcribed, stored in a retrieval system or translated into any language in any form by any means without the prior written consent of Garnet Instruments. Information in this manual is subject to change without notice and does not represent a commitment on the part of Garnet.

1.0 INTRODUCTION

1.1 Overview

The SeeLevel 808-P2 Display is a gauge mounted on trucks, providing real-time liquid level readings from the sender bar. When utilized with the 810-TX sender bar, it additionally monitors the temperature inside the tank. It facilitates safe loading with controls for a customizable warning alarm, and emergency overfill shutdown protection. It can be used alone, or in conjunction with Garnet's SpillStop or MultiRack systems.



Figure 1.1.2a 808-P2 (Rev M) Display

1.2 Features and Benefits

- Works with the 810-X or 810-TX sender bar (installed within the tank).
- Fiber optic signals enhance safety and make it suitable for flammable liquids in hazardous locations.
- Mounts externally on the truck/trailer for easy viewing.
- Fluid level is continuously displayed.
- Liquid temperature viewable with a press of a button (810-TX only).
- Programmable alarm thresholds that can be configured for Normally Open or Normally Closed (24 VDC at 1A) and used for a warning horn or other suitable devices when the liquid level reaches a programmable threshold.
- Emergency shutdown control when liquid level reaches programmable maximum threshold.
- Can be used to control SpillStop or MultiRack for increased overfill protection.
- **New features of the 808-P2 (Rev M)** include compatibility with both the 810-X and 810-TX (coming soon), automatic configuration for each bar, displays temperature readings from the 810-TX Sender Bar, and an updated alarm circuit with resettable fuses to prevent damage from wiring shorts or connection to devices that exceed the available 24VDC at 1A current limit.
- **The 810-TX sender bar** includes an increased resolution from 1/3" to 1/4", along with temperature sensors providing fluid level temperature to +/- 0.5°C (±0.1°F), a field-replaceable battery module, and will require the 250-STAT-FLOAT. The SeeLevel 808-P2 Rev M or newer is required to take full advantage of all the new features of the 810-TX.



2.0 QUICK GUIDE

2.1 Operation

The sender bar is installed vertically inside the tank. As the liquid level changes, the float will move up and down the sender bar. Magnets within the float allow the sender to accurately measure the position of the float, and translate that into the liquid level. Embedded temperature sensors also measure the liquid temperature. The liquid level and temperature are continuously transmitted to the SeeLevel gauge through the fiber optic cable. The gauge displays the volume of liquid within the tank based on this reading. The temperature of the liquid can be viewed by pressing the button on the side of the display (810-TX only). If the button is held down for 2 seconds, the battery status of the sender bar is displayed.

Every tank shape is different, and the display can be set to common volumetric units such as gallons, cubic meters, or barrels. To calibrate the SeeLevel for your tank, please see the 817-USB SeeLevel Truck Gauge Programmer documentation.

NOTE: SeeLevel Transport systems do not require re-calibration after initial setup because of their digital design using reed switch technology. The calibration chart supplied by the tank manufacturer, including the tank size and capacity, is used to size the sender bar and program the SeeLevel display. After installation into the tank it has been configured for, the calibration does not drift and therefore does not require recalibration.

2.1.1 Alarms

The SeeLevel contains internal alarm points that can be set to custom levels to warn the user when the liquid level is approaching its maximum level, and to shut off a pump if the tank is full.

As the liquid in the tank rises during loading, it will reach the warning threshold (alarm 2). When this happens, the SeeLevel triggers the alarm 2 output. This output can be used to turn on a warning light, or horn, etc. This alarm can be bypassed by pressing the button on the gauge. If it is bypassed, it remains in bypass until the tank is emptied below the "reset" threshold (alarm 3).

If the liquid level increases to the "full" threshold, the emergency output (alarm 4) is triggered, which can be used as an emergency shutoff for a pump, to prevent overflow. This alarm cannot be bypassed. The alarm will deactivate once the liquid level goes below the alarm 4 threshold.

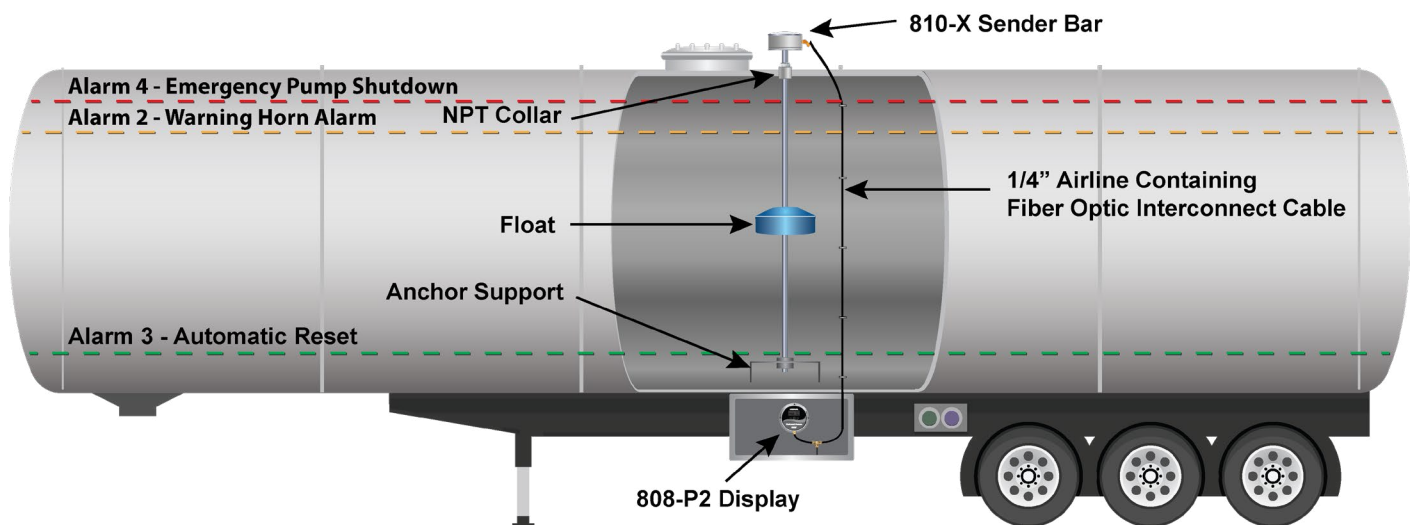

Figure 2.1.1a General Operation

ALARM FUNCTIONS

ALARMS	TYPE	FUNCTION
Alarm 1	For SpillStop Use	Used only when connected to a SpillStop for Enhanced overfill protection. Programmable set point. (Green wire).
Alarm 2	Warning Horn	Programmable alarm. Will toggle on/off at the set point. Can be bypassed. While triggered if the bypass button is pressed the alarm condition will be latched until the tank level is brought below the set point for Alarm 3 (reset). (Purple wire)
Alarm 3	Auto Reset	Programmable reset. Will clear Alarm 2 once below the set point.
Alarm 4	Pump Shutdown	Programmable shut off. Will toggle on/off at the set point. Provides basic overfill protection and only used if the 808-P2 is being used in a standalone configuration. (i.e. without a SeeLevelL SpillStop). Cannot be bypassed. This alarm is used to lock out the pump. (Yellow wire).

2.2 View Firmware Revision, Mode and Temperature (Rev M)

To view the mode settings, ensure that the display is reading "n L", then place a magnet over the "v" in "SeeLevelL" on the front label. Continue to hold the magnet and the display will begin to scroll through the menu. The magnet can also be placed on the backside of the lid where it indicates "*place magnet here to change mode*".

View Firmware revision 8.19 or higher.

Once the magnet is in the correct position, the LCD screen will then display the Firmware revision. 'r8.19' or higher.

View Classic or Enhanced mode

If you continue to hold the magnet in place the LCD will then display the current mode for the calibration. The 808-P2 will be in either classic "P L R" mode or enhanced "E n H R" mode. Both modes allow for offsets and alarm points to be used, but enhanced mode offers some more advanced functionality. This setting can only be changed with the 817-USB programmer, and further details can be found in the 817-USB programmer manual.

View or set Temperature to Fahrenheit or Celsius

Finally, the menu will display the temperature setting. The LCD will display "L F" (Current Temperature Fahrenheit) or "L C" (Current Temperature Celsius). To change the temperature setting continue to hold the magnet in place. The LCD will display "P C" (Program Celsius) then "P F" (Program Fahrenheit). Remove the magnet when the desired setting is display. The LCD will flash "S O R", storing the setting.

3.0 INSTALLATION GUIDE

3.1 Sender Bar Assembly

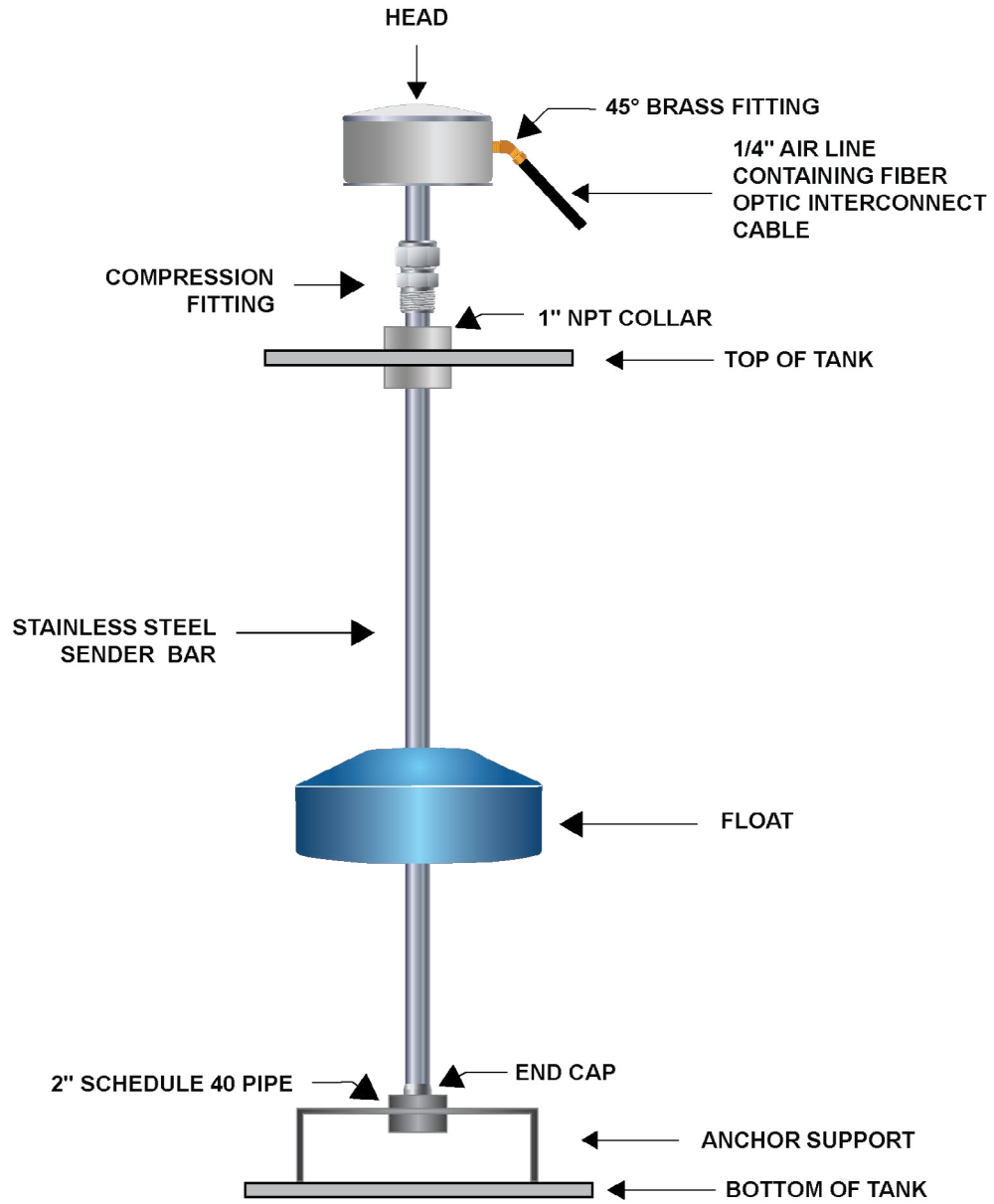

Figure 3.1.1a Sender Bar Assembly

3.2 Tank Preparation

3.2.1 Determine sender bar mounting position

1. Select a central location in the tank for mounting the sender bar, ensuring proximity to the tank’s midpoint and allowing space for the head at the top. (See Figure 3.2.1a)
2. Ensure the float won’t encounter any tank baffles or obstructions.
3. Preferably, position the float for hatch accessibility to facilitate service work; avoid mounting it behind baffles that restrict hatch access. (See Figure 3.2.1b)

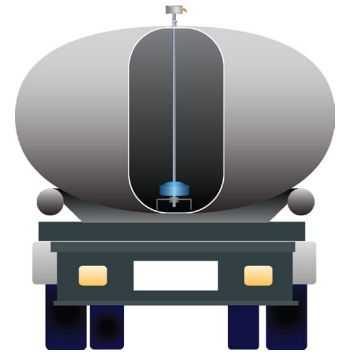

Figure 3.2.1a Bar location - back view

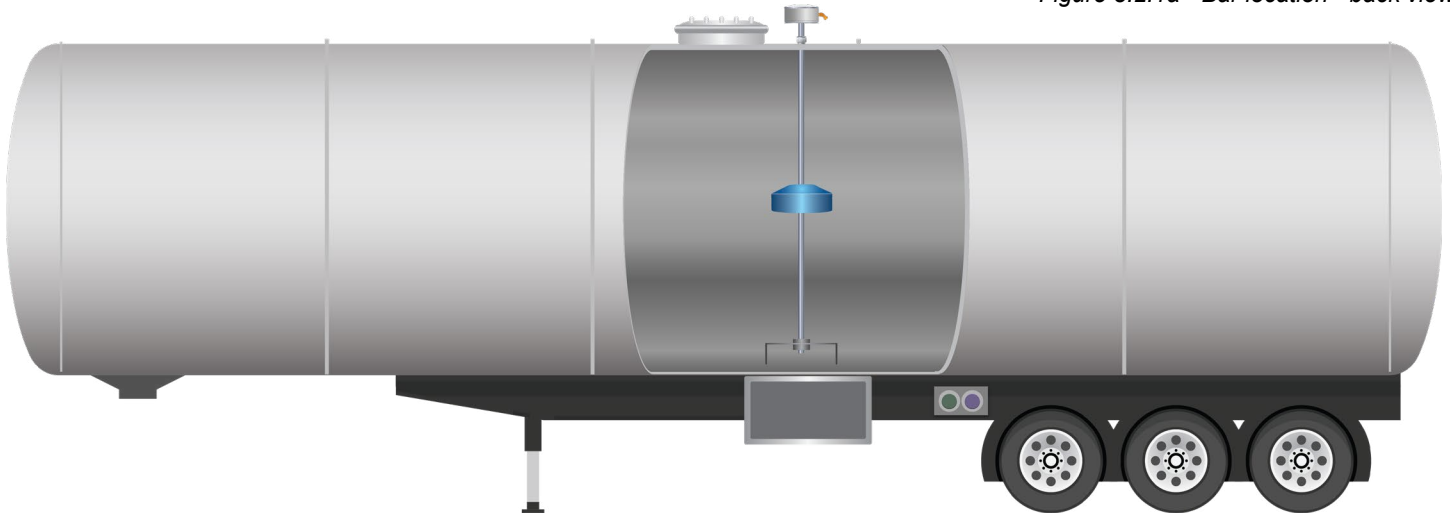

Figure 3.2.1b Bar Location - side view

3.2.2 Install NPT Collar and Float Support

1. Drill a hole and weld NPT collar into place at top of the tank.(See Figure 3.2.2a)
2. Mount float support at the bottom of the tank. Ensure NPT collar and anchor are aligned. For float support fabrication (See Figure 3.2.2b).

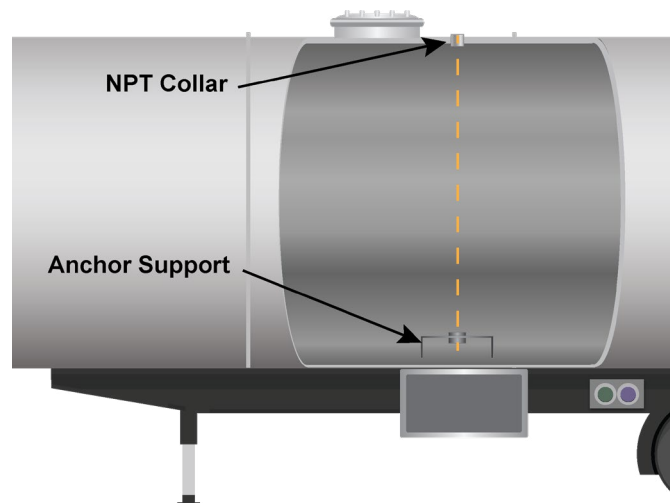

Figure 3.2.2a Install NPT Collar and Float Support

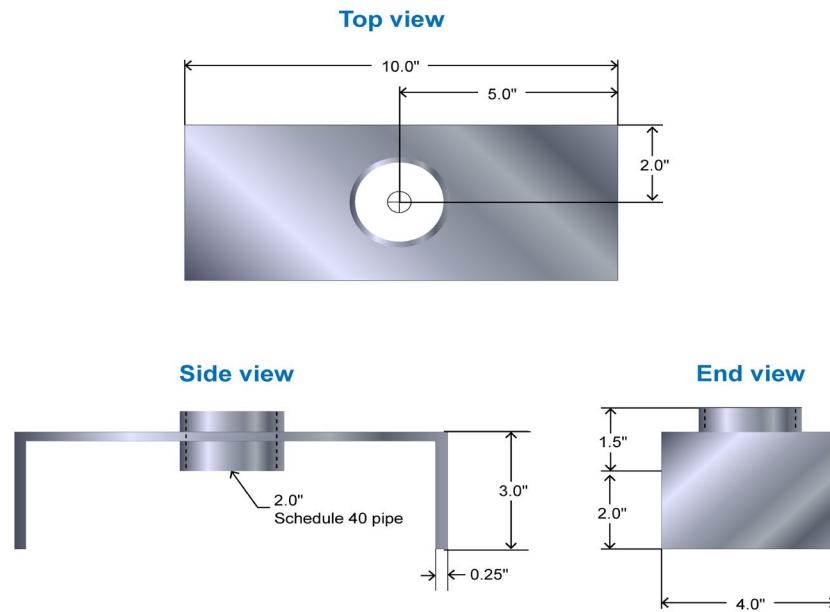

Figure 3.2.2b Float Support Fabrication

3.2.3 Cutting the Bar

⚠ NOTE: The sender bar needs to be cut to length for specific trailers. Contact a sales or service rep for cut options.

3.2.4 Sender Bar Installation

1. Guide the sender bar through the NPT collar. Ensure the compression fitting is on the bar, then through the float anchor support until it hits the bottom of the tank.
2. Raise the bar 2" up from the bottom of the tank to accommodate tank flex that could mechanically interfere with the bottom of the bar. (See Figure 3.2.4a)

Figure 3.2.4a Install Sender Bar

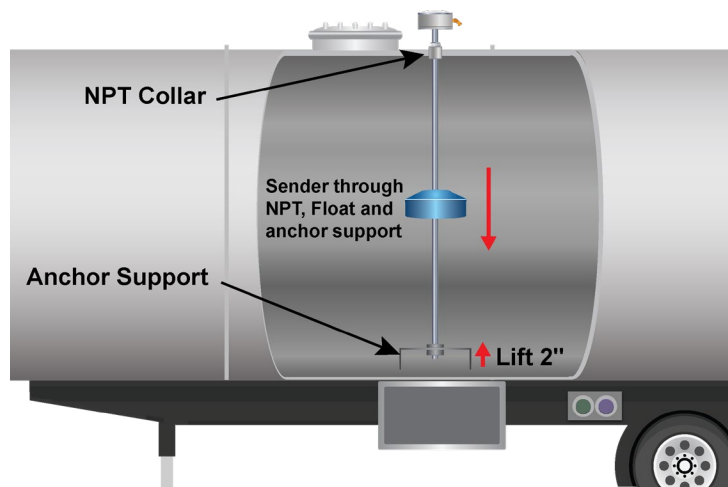

⚠ CAUTION: Installing the bar less than 2" from the bottom of the tank WILL result in premature sender bar failure that is not covered under warranty.

3.3 Mount the Display

1. Select a location for the display. It should be easy to see and out of direct road spray and protected from driving rain.
2. The display enclosure should be mounted using the mounting flange holes. If the holes are not pre-drilled in the display enclosure, drill holes into the enclosure close enough to the base to avoid contacting the lid flange (See Figure 3.3.4b).
3. Make sure that the lid is not on the box when drilling to avoid damaging the display electronics.

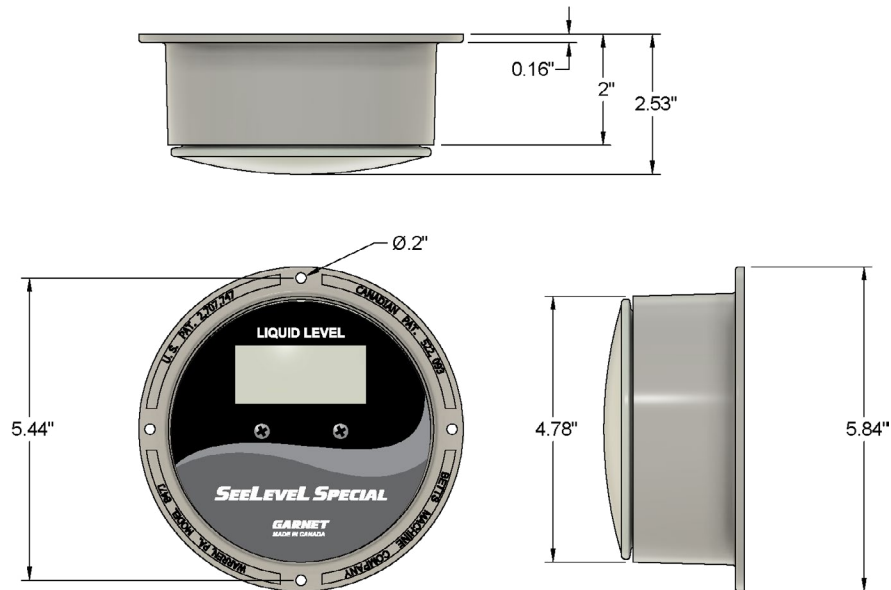

Figure 3.3.4a Display Schematic

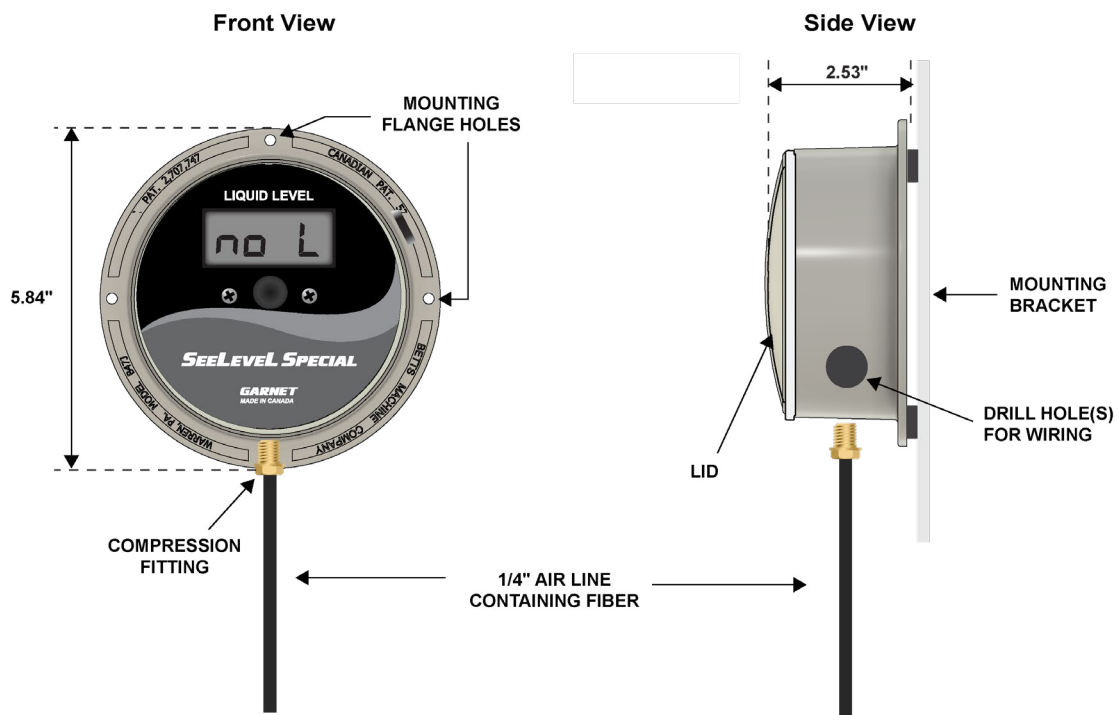

Figure 3.3.4b Display Assembly

3.3.5 Connect the Airline Hose

1. At the lowest point in the airline, insert a T-fitting with approximately two feet of 1/4" airline hanging down to create a drain/vent for any moisture that may enter or build-up in the system.
2. If a T-fitting is not practical, install a fitting into the bottom of the display enclosure and route the 2 feet of 1/4" airline hose from there. (See Figure 3.3.5a)

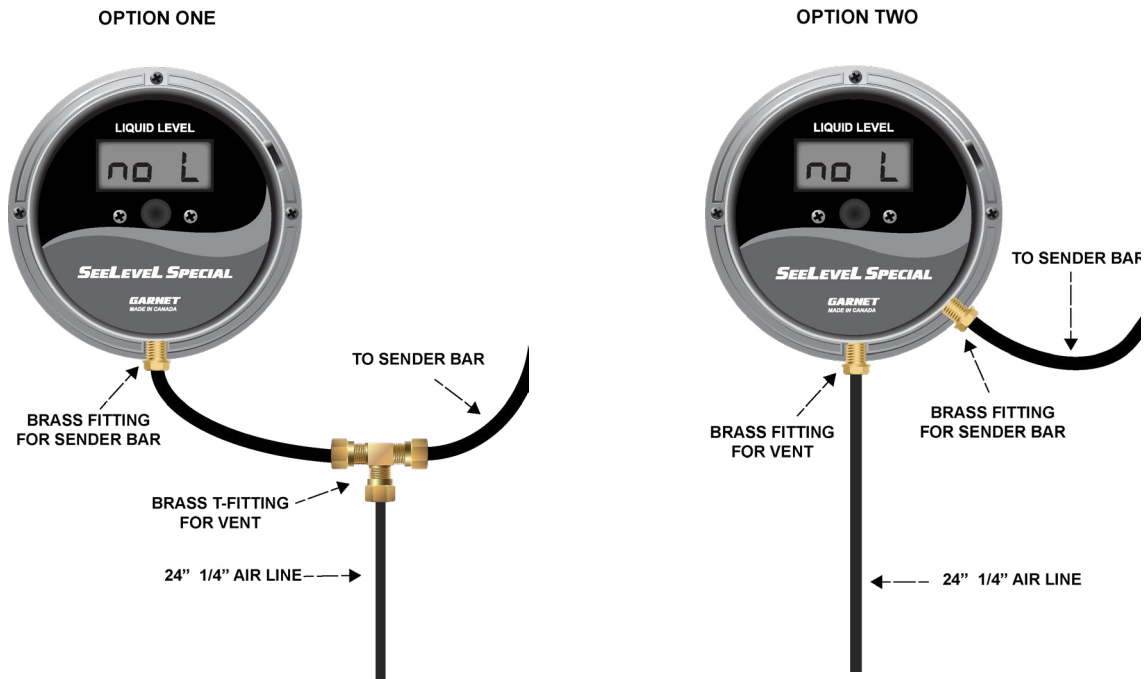

Figure 3.3.5a Airline Hose Options

3.4 Install Fiber Optic Cable

3.4.1 Preparation of Fiber Optic Cable

1. Use a piece of 1/4" airline hose to protect the black fiber. With the airline hose straight, insert and feed the fiber optic cable through the hose, leaving 12" extra at each end (See Figure 3.4.1a).
⚠ CAUTION: Maintain the largest possible radius within the enclosure. Bends should never exceed 90°; sharp bends or kinks will reduce the amount of signal passed.



Figure 3.4.1a Fiber Optic Cable Inserted Through Airline Hose

3.4.2 Connect the Fiber to Display Enclosure

1. Insert the fiber through the brass fitting and into the enclosure, leaving an extra 6 - 8 inches of fiber coiled inside.
2. Position the airline hose so it abuts the brass fitting. (See Figure 3.4.2a)



Figure 3.4.2a Fiber Optic Cable in Enclosure

3.4.3 Plug Fiber to the Receiver Connector

1. Flip the lid over to expose the back side.
2. Loosen the compression nut on the black optic receiver.
3. Ensure the end of the fiber is clean. Carefully insert the fiber into the black optic receiver until it sits flush against the optic lens.
4. Tighten the compression nut securely. (See Figure 3.4.3a)

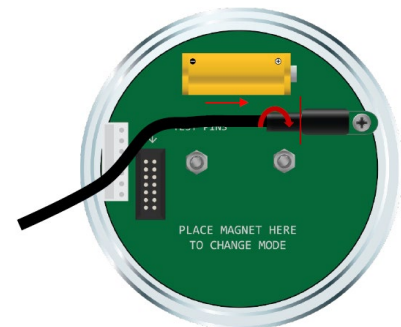

Figure 3.4.3a Fiber connected to Gauge Optic Receiver

3.4.4 Connect Fiber Optic Cable to Sender Bar Head

1. Use the supplied 45°, 1/4" brass fitting.
2. Remove the lid from the sender bar head enclosure
3. Insert the fiber leaving 6 - 8" extra fiber inside the head of the bar. (Coil around inside the head once)
4. Loosen the compression nut (lefty-loosy, righty-tighty) on the white optic transmitter.
5. Ensure the end of the fiber is clean.
6. Gently, plug the fiber into white optic transmitter until seated flush against the optic lens.
7. Tighten the compression fitting. (See Figure 3.4.4a)

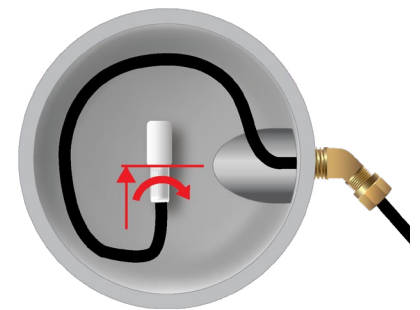

Figure 3.4.4a Fiber Connected into Optic Transmitter in Bar

3.4.5 Install Airline on the Truck

1. Route the 1/4" airline from the sender bar head to the display. Avoid bends tighter than 90° and do not kink. (See Figure 3.4.5a) Airline can be routed either to the side of the tank to the display (Option 1), or to the back of the tank, down and then to the display (Option 2).
2. Ziptie the airline to the tank truck.

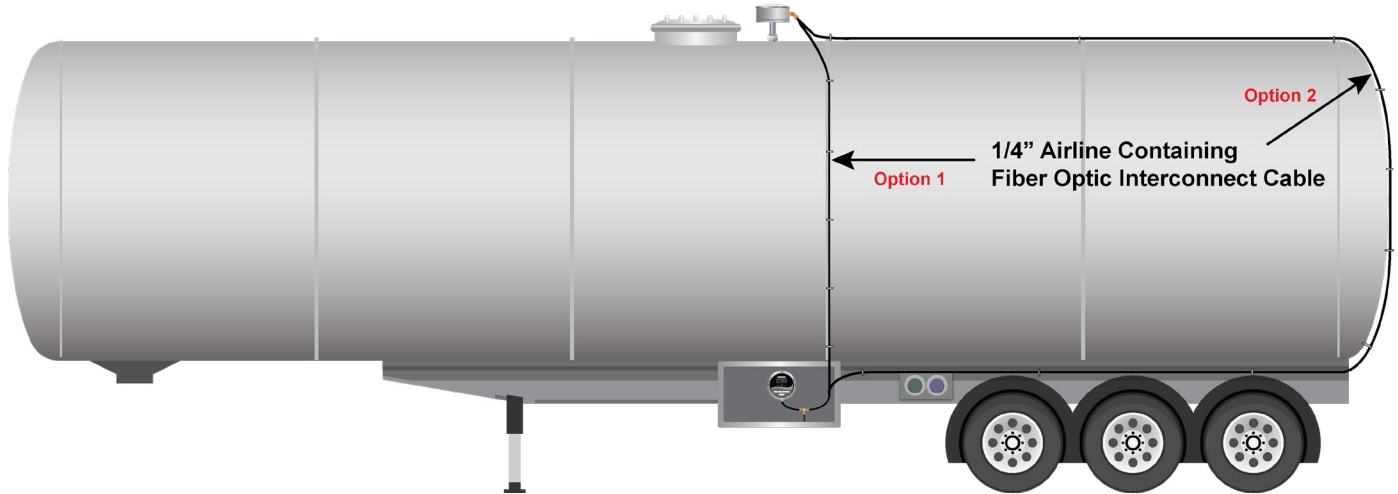

Figure 3.4.5a Airline Routed from Sender Bar to Gauge

3.5 Program the Display

1. Refer to the 817-USB Truck Gauge Programmer Manual for programming instructions.

3.5.6 Verification of Bar Operation

1. With the Opto pointing upward, place a magnet against both the head plate and the tube. (See Figure 3.5.6a)

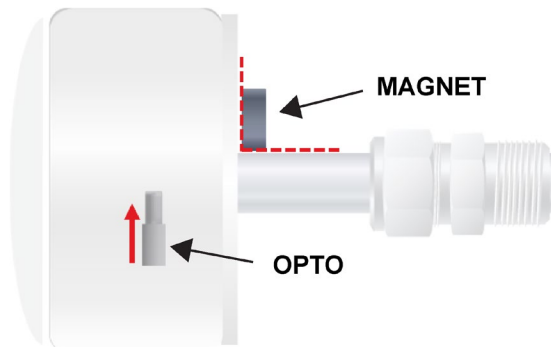
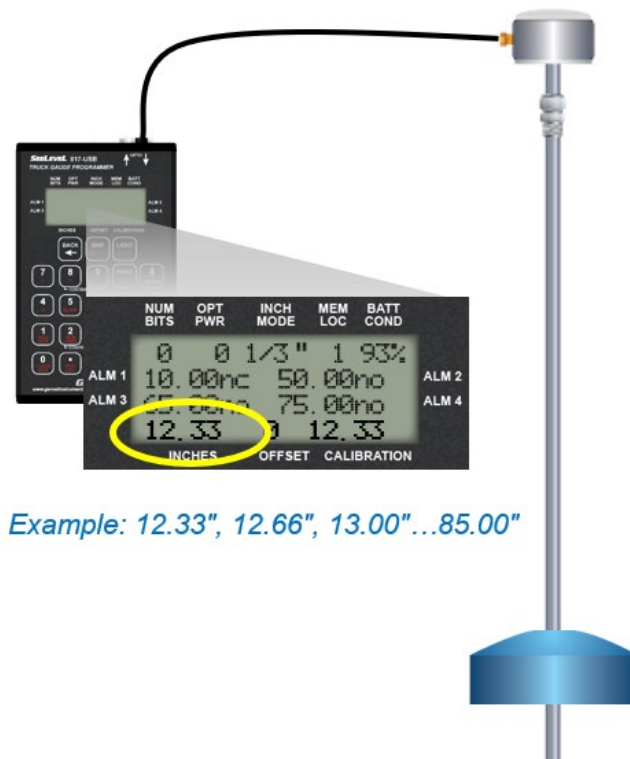

Figure 3.5.6a Magnet Placement

2. Move the float on the bar up and down to ensure proper functioning. (See Figure 3.5.6b)



Example: 12.33", 12.66", 13.00"...85.00"

Figure 3.5.6b Verifying Bar Operation

3. Correct operation is confirmed when there is engagement every 1/3 of an inch for 810-X, or 1/4 of an inch for 810-TX, on the 817-USB Truck Gauge Programmer. (See Figure 3.5.6c)

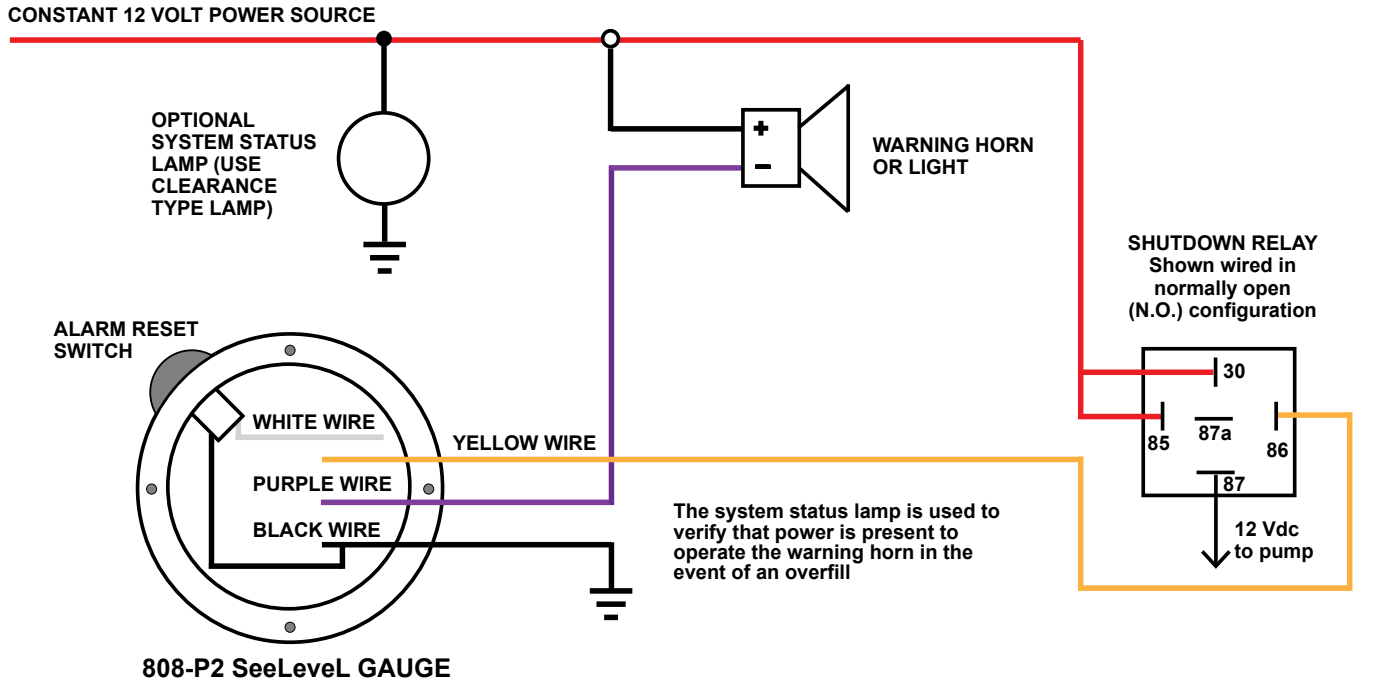

Figure 3.5.6c Fiber from Sender Bar plugged into 817-USB Truck Gauge Programmer

3.6 Wiring Diagrams

3.6.1 Common Configuration

AUTOMATIC ALARM WIRING DIAGRAM



AN ADDITIONAL RELAY IS NEEDED IF THE HORN OR LIGHT DRAWS MORE THAN 1 AMP AT 12 VDC

Figure 3.6.1a Automatic Alarm Wiring Diagram

4.0 MAINTENANCE AND SERVICE INFORMATION

4.1 O-Ring

The 808-P2 relies on an O-ring to keep water out of the enclosure. To ensure long term reliability of the display, this O-ring must be kept lubricated with a silicone based grease. Check the display regularly and apply grease as needed.

⚠ CAUTION: All enclosures with an o-ring must be cleaned and greased periodically. WATER DAMAGE IS NOT WARRANTABLE.



4.2 Brass Fitting

The brass fitting should only be screwed into the display housing until it is flush with the interior surface. This ensures that any water that enters the display housing can drain effectively.

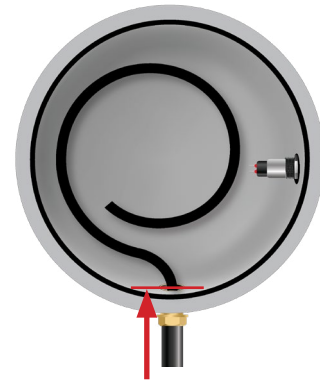

4.3 Cleaning Display

Never spray directly at the display with a pressure washer. Cover the display if the tank is being cleaned with water pressure.

4.4 1/4" Airline

Refer to (See Figure 3.4.1a) to learn about installing a vent to help keep water out of the display.

5.0 TROUBLESHOOTING GUIDE

5.1 Diagnostic Flowchart

Refer to a separate document called “808-P2 troubleshooting flow chart”. The flowchart can be used to perform basic troubleshooting on the SeeLevel gauge system. Some steps may require the use of an 817-USB truck gauge programmer. More advanced testing is also covered in the 817-USB documentation.

5.2 FAQs

5.2.1 Why does my display read “No L”?

no L = no Light condition. The display is working, but either the fiber is unable to send the signal from the bar or the bar is no longer sending the signal through the fiber.



5.2.2 Why does my display read “bL” and then a number?

bL = bad Light condition. It means the display is not working properly or that it is not getting a good signal from the bar. Remove the fiber from the display. If the display continues reading BL and a number, then the display needs to be replaced. If it goes to no L or Sun, then start from one end and cut a 1/4" from each end of the fiber to eliminate dirty or damaged fiber ends. Try blowing out the opto with some super duster or filtered shop air to see if it solves the problem.



5.2.3 Why does my display read “Sun”?

Sun = Sun. This message could mean the display is not working properly or that the fiber optic receiver is getting too much light. Cut a 1/4" from the end of the fiber that is plugged into the display. If the display starts working, then the problem is solved. If not, then the display could be the issue and needs to be replaced. Can also be caused by constant light from bar=bad bar or fiber is cut allowing actual Sun Light into the fiber line.



5.2.4 Why is my display blank?

This could simply be a blank spot in the programming and the offset needs to be adjusted. An easy way to find out is by unplugging the fiber from the display. If the display shows Sun or no L when the fiber is unplugged, then it means the display is working correctly and the offset needs to be adjusted. If it stays blank, then the display is bad and needs to be replaced.



5.2.5 Why does the reading jump around when the tank is being filled?

This could be an issue with the calibration chart that was programmed into the display. If the display was reading correctly and this is a new issue, then it is possibly a bar issue. Contact service for information.

5.2.6 Why does my display seem to be stuck on a number?

Water damage can cause the display to get stuck and not show a correct reading. Could also be a corrupt bar sending bad data. Water damage inside the head or endcap leaking fluid into the circuit

5.2.7 How to contact service?

Call 1-800-617-7384
or email us at
support@garnetinstruments.com

6.0 SYSTEM SPECIFICATIONS

DISPLAY		
Material	Enclosure: PBT plastic Lid: polycarbonate	
Size	Enclosure size: 152 mm (6") diameter, 67 mm (2 ⁵ / ₈ ") deep.	
Display type	Wide temperature LCD, 4 digit, 7 segment	
Display size	12.7 mm (½") high digits	
External power	Light behind the LCD is powered by 12 Vdc truck power	
Battery power	Powered by a lithium battery, which is not field replaceable but is replaceable, with a lifetime of approximately 10 years	
Ambient temperature range	-40°C to +60°C (-40°F to +140°F) ambient	
SENDER BAR	810-X	810-TX
Resolution	8 mm (½")	6 mm (¼")
Accuracy	+/- 6 mm (+/- 0.25")	+/- 5 mm +/- 0.2")
Sender Bar	Bar: 316 stainless steel seamless tube Enclosure: PBT plastic, lid is polycarbonate Fitting: 25 mm (1") NPT male compression fitting.	
Float	Material: Medium density polyethylene. Stainless steel float available (optional upgrade). Size: Cylindrical, 216 mm (8 1/2") in diameter, 89 mm (3 1/2") high. Buoyancy: Sinks 25 mm (1") in water.	Material: Medium density polyethylene. Stainless steel float available (optional upgrade). Size: Cylindrical, 117.8 mm (7") in diameter, 101.6 mm (4") high. Buoyancy: Sinks 37.5 mm (1.5") in water.
Maximum tank height	Tank height up to 221 cm (87")	
Battery power	Powered by a lithium battery, which is not field replaceable but is replaceable, with a lifetime of approx. 10 years	Powered a field replaceable lithium battery module with a lifetime of approx. 10 years
Product temperature range	-40°C to +90°C (-40°F to +194°F)	
COMPLIANCE & CERTIFICATIONS		
CAN ICES:	CAN ICES-001(A)/NMB-001(A)	
FCC:	This device complies with part 15 of the FCC Rules. Operation is subject to the following two conditions: (1) This device may not cause harmful interference, and (2) this device must accept any interference received, including interference that may cause undesired operation. Changes or modifications not expressly approved by the party responsible for compliance could void the user's authority to operate the equipment.	
PROP65	This product can expose you to chemicals including Nickel and Lead, which are known to the State of California to cause cancer, and lead which is known to the State of California to cause birth defects or other reproductive harm. For more information go to www.P65Warnings.ca.gov	

6.1 Parts List for Installation

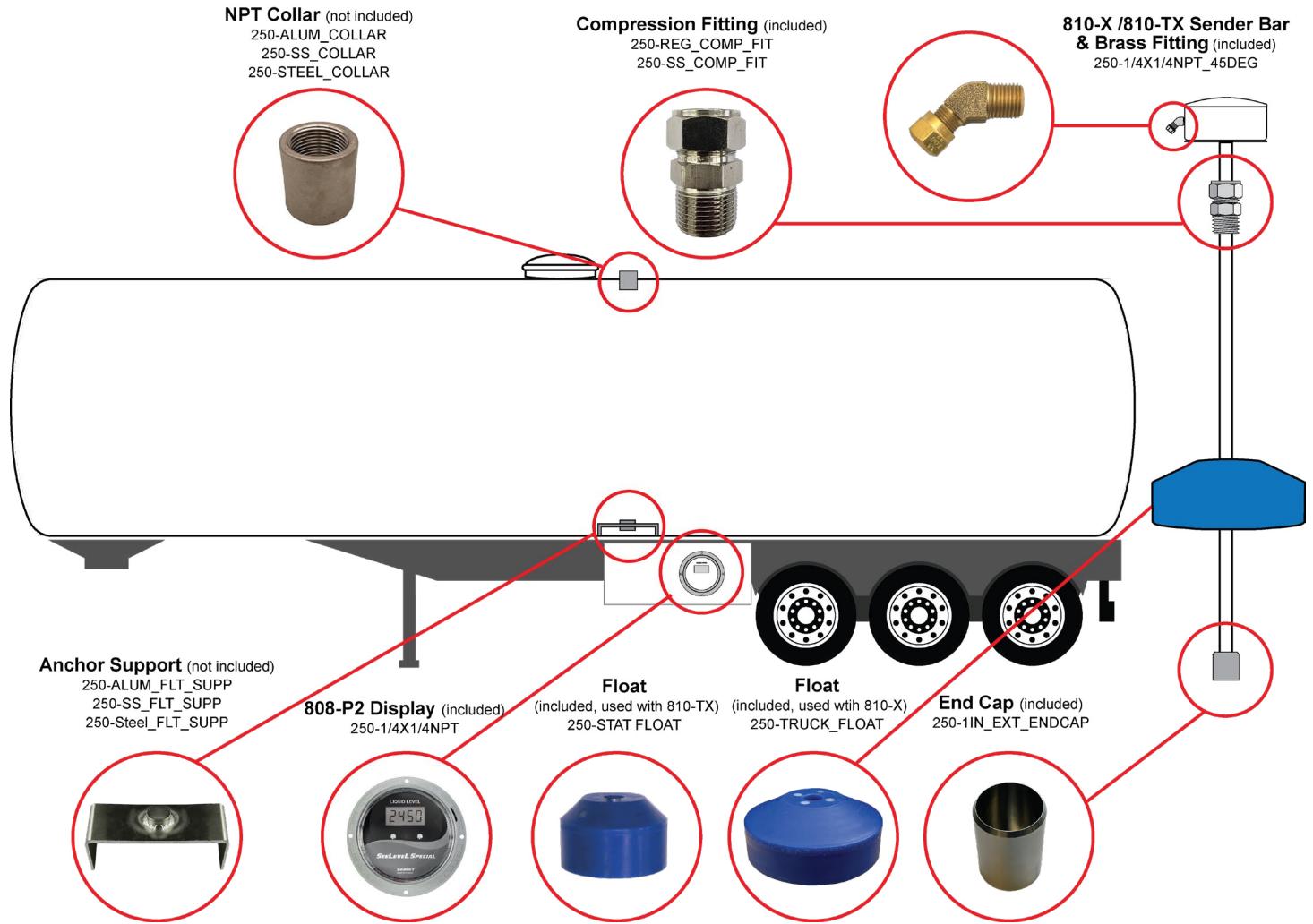

6.2 Safety Information

Any electrical connections or disconnects must be done in an ordinary location (i.e. not HazLoc)

6.3 Warnings and Cautions

Read these instructions carefully and look at the equipment to become familiar with the device before trying to install, operate, service, or maintain it. The following special messages may appear throughout this manual or on the equipment to warn of potential hazards or to call attention to information that clarifies or simplifies a procedure. "Notes", "Cautions", and "Warnings" have been used to bring special matters to the immediate attention of the reader.

 **NOTE:** expands on information for any procedures.

 **CAUTION:** explains safety information that could cause damage to the product, including data loss.

 **WARNING:** explains dangers that might result in personal injury or death.

6.4 Notice of Limited Liability

The 808-P2 provides real-time liquid level readings and will provide discrete outputs at set alarm levels. When paired with an 810-TX bar the 808-P2 can also provide fluid level temperature.

The 808-P2 is designed to assist the operator during the loading and unloading but does not absolve the operator from being responsible for the process.

The information provided in this manual describes typical installation and use cases, but the end-user is responsible to ensure the suitability of the equipment for their application.

Garnet Instruments shall not be liable for any ancillary, consequential, direct, or indirect damages arising from the use of their products. This includes but is not limited to the loss of profits, business interruption, loss of product, product contamination, or damage to other related equipment or systems. By purchasing Garnet Instruments products or services the customer acknowledges and accepts the terms outlines in this notice.

7.0 WARRANTY

To find warranty claim process information, refer to our support page on our website:

www.garnetinstruments.com/support/

DISCLAIMER OF WARRANTY ON HARDWARE

Garnet Instruments Ltd. warrants equipment manufactured by Garnet to be free from defects in material and workmanship under normal use and service for a period of three years from the date of sale from Garnet or an Authorized Dealer. The warranty period will start from the date of purchase or installation. Under these warranties, Garnet shall be responsible only for actual loss or damage suffered and then only to the extent of Garnet's invoiced price of the product. Garnet shall not be liable in any case for labor charges for indirect, special, or consequential damages. Garnet shall not be liable in any case for the removal and/or reinstallation of defective Garnet equipment. These warranties shall not apply to any defects or other damages to any Garnet equipment that has been altered or tampered with by anyone other than Garnet factory representatives. In all cases, Garnet will warrant only Garnet products which are being used for applications acceptable to Garnet and within the technical specifications of the particular product. In addition, Garnet will warrant only those products which have been installed and maintained according to Garnet factory specifications.

LIMITATION ON WARRANTIES

These warranties are the only warranties, expressed or implied, upon which products are sold by Garnet and Garnet makes no warranty of merchantability or fitness for any particular purpose in respect to the products sold. Garnet products or parts thereof assumed to be defective by the purchaser within the stipulated warranty period should be returned to the seller, local distributor, or directly to Garnet for evaluation and service. Whenever direct factory evaluation, service or replacement is necessary, the customer must first, by either letter or phone, obtain a Returned Material Authorization (RMA) from Garnet Instruments directly. No material may be returned to Garnet without an RMA number assigned to it or without proper factory authorization. Any returns must be returned freight prepaid to: Garnet Instruments, 286 Kaska Road, Sherwood Park, Alberta, T8A 4G7. Returned warranted items will be repaired or replaced at the discretion of Garnet Instruments. Any Garnet items under the Garnet Warranty Policy that are deemed irreparable by Garnet Instruments will be replaced at no charge or a credit will be issued for that item subject to the customer's request.

If you do have a warranty claim or if the equipment needs to be serviced, contact the installation dealer. If you do need to contact Garnet, we can be reached as follows:

CANADA

Garnet Instruments Ltd.
286 Kaska Road
Sherwood Park, AB T8A 4G7
CANADA
email: info@garnetinstruments.com

UNITED STATES

Garnet US Inc.
5360 Old Granbury Road
Granbury, TX 76049
USA
email: infous@garnetinstruments.com